

**HYDRAULIC
HOSE
ASSEMBLY
SPECIFICATION
GUIDELINES**

THE ASSOCIATION FOR HOSE AND
ACCESSORIES DISTRIBUTION



THE ASSOCIATION FOR HOSE AND
ACCESSORIES DISTRIBUTION

NAHAD 700
2005

IMPORTANT NOTE TO READER:

NAHAD - The Association for Hose and Accessories Distribution - is pleased to provide this *comprehensive set of basic Hose Assembly Specification Guidelines* for customers seeking to acquire fabricated hose assemblies for various industrial applications. The information contained within this document has been developed through the concerted efforts of dozens of member volunteers, association staff and industry leaders, with the common goal of helping to improve the safety, quality and reliability of fabricated hose assemblies.

In addition to this document, NAHAD has produced four other Hose Assembly Specification Guidelines publications, addressing a total of five hose product groups, including: Composite Hose; Corrugated Metal Hose; Hydraulic Hose; Industrial Hose and Fluoropolymer Hose. These five publications are intended to complement existing industry and federal regulations. Aerospace and hydraulic brake hose assemblies are specifically excluded from this and the other four documents.

Hose, hose fittings and hose couplings come in various sizes and designs. Although there are standards published by manufacturers and independent testing organizations, such as ANSI, ASME, ASTM, ASQ, UL, ISO, SAE, RMA and others which relate to hoses and hose fittings, there are no generally recognized standards for hose assemblies. This publication is indebted to these organizations and, in specific cases, refers the reader to designated existing standards and recommendations provided by these other sources in an attempt to encourage the fabrication of safer, higher quality and more reliable hose assemblies.

NAHAD has published these Hose Assembly Specification Guidelines in order to create reference works that compile information of value to NAHAD members, manufacturers and customers in developing hose assemblies that meet specific individual needs. To the extent that each assembly has unique characteristics, it must be custom designed, engineered and tested. Hopefully, these Guidelines will be useful in the process.

In compiling standards and recommendations published by others and in developing these Guidelines, NAHAD has not and will not engage in independent testing or verification of the information provided to it. Users of these Guidelines should not, and cannot, rely on these Guidelines as a standard, certification or approval of the data published herein. NAHAD, and the member company volunteers, association staff and industry leaders who participated in the creation of these Guidelines do not assume, and expressly decline and deny, any and all liability for any product failures, damages or injuries that may result in any way from utilization of these Guidelines or products based on these Guidelines.

The NAHAD Hose Assembly Guidelines incorporate various technical recommendations published by other sources. NAHAD has not independently verified these recommendations and specifically disclaims any and all liability, direct or indirect, for any failures, damages or injuries resulting in whole or in part from the failure of any product, including hoses, fittings, and assemblies described in this publication or in the Guidelines.

© Copyright 2005 by The Association For Hose & Accessories Distribution, Inc. (NAHAD). All rights reserved. No part of this publication may be reproduced, stored in a retrieval system, or transcribed, in any form or by any means, electronic, mechanical, photocopying or otherwise, without the prior written permission of NAHAD.

Published by The Association For Hose & Accessories Distribution, Inc.
105 Eastern Avenue, Suite 104
Annapolis, Maryland 21403
www.nahad.org

Table of Contents

Section 1 – Scope	5
Section 2 – Hydraulic Hose Assembly Component Selection	5
2.1 Industry Standards	5
2.1.1 Hose	5
2.2.1 Couplings	7
2.2 Application Requirements - STAMPED	7
2.2.2 General	7
Section 3 – Hydraulic Assembly Specifications	9
3.1 Overall Assembly Length	9
3.2 Hose Assembly Orientation for Offset Elbow Fittings	10
3.3 Cleanliness	11
3.4 Identification (Labeling and Marking)	11
3.5 Packaging	11
Section 4 – Quality Plan	12
4.1 Sampling Plan	12
4.1.1 Dimensional Inspection	13
4.1.2 Physical Testing	13
4.2 Final Assembly Inspection	14
4.3 Storage (Labeling, Environment, Time)	14
4.4 Documentation	15
Section 5 – Assembly Installation and Procedures	15
5.1 Safety Considerations	15
5.1.1 Media Permeation	16
5.1.2 Fluid Injections	16
5.1.3 Whipping Hose	16
5.1.4 Fire and Explosions from Conveyed Fluids	16
5.1.5 Fire and Explosions from Static-Electric Discharge	16
5.1.6 Burns from Conveyed Fluids	17
5.1.7 Electrical Shock	17
5.1.8 Fluid Controlled Mechanisms	17
5.1.9 Hand-held Hydraulic Operated Tools	18
5.2 Hose Installation and Replacement	18
5.2.1 Pre-Installation Inspection	18
5.2.2 Handling During Installation	18
5.2.3 Hose Routing	19
5.2.4 System Checkouts	20
5.3 Maintenance Inspection	20
5.3.1 Inspection Frequency	21
5.3.2 Visual Inspections	21
5.3.3 Visual Inspections for All Other Components	21
5.3.4 Functional Tests	21
APPENDIX A – Glossary	22
APPENDIX B – Stamped Form	41
APPENDIX C – Nomographic Flow Chart	42

APPENDIX D – Pressure Conversion Chart	43
APPENDIX E – Hose Ends	44
APPENDIX F – References	59

Section 1 – Scope

This NAHAD Guideline is intended to complement existing industry standards and federal regulations. This document recommends methods and requirements necessary for the selection of components, fabrication, and testing of hose assemblies and pertains to hydraulic hose and hydraulic hose assemblies.

Hydraulics can be simply defined as the science of using fluid, under pressure, to do work. Hydraulic hose assemblies are flexible, fluid power connectors used to convey and direct these fluids. Today, hydraulics has progressed to where it is used in agriculture, construction, metal working, marine, forestry, mining and practically any other industry you can name.

This section recommends the methods and requirements necessary for the selection, fabrication and testing of hydraulic hose assemblies and pertains to nominal internal diameters 1/8 inch through 4 inch (3.2 mm through 101.6 mm).

It is extremely important that the specific instructions of the hose and coupling manufacturers be followed! Therefore, the practice of “mixing and matching” hose and couplings from different manufacturers is strictly prohibited, unless the combination of components has been fully qualified to industry standards and approved by the respective manufacturers. In no instance should the information printed in this section supercede manufacturer’s instructions.

This document is not intended to prohibit either fabricator or end user from including additional requirements for hydraulic hose, couplings or hydraulic hose assemblies, if necessary, to satisfy the application. It is the responsibility of each fabricator and user to define these applications and their requirements to ensure performance capability.

Note: Aerospace and hydraulic brake hose assemblies are excluded from the scope of this section.

Section 2 – Hydraulic Hose Assembly Component Selection

2.1 Industry Standards

2.1.1 Hose

Many hydraulic hose styles are available and are described in detail in the component manufacturer’s catalogs. The most common and popular hose are manufactured to the SAE J517 100R series and EN hose standards which are summarized in Table 2.1.1

However, in addition to these hose types, there are a great many new styles and constructions that have been developed in the last 20 years to meet almost every possible condition imaginable.

TABLE 2.1.1

SAE HOSE WORKING PRESSURES (psi)

Specification	Hose Style	Description	NOMINAL HOSE INSIDE DIAMETER in INCHES and DASH SIZE															
			3/16 (-3)	1/4 (-4)	5/16 (-5)	3/8 (-6)	1/2 (-8)	5/8 (-10)	3/4 (-12)	1 (-16)	1-1/4 (-20)	1-1/2 (-24)	2 (-32)	2-1/2 (-40)	3 (-48)	3-1/2 (-56)	4 (-64)	
SAE J517	100R1	1 WIRE BRAID	3000	2750	2500	2250	2000	1500	1250	1000	825	500	375					
SAE J517	100R1 TYPE S	HIGH PRESSURE 1 WIRE BRAID	3630	3260	3120	2610	2320	1890	1520	1280	910	730	580					
SAE J517	100R2	2 WIRE BRAID	5000	5000	4250	4000	3500	2750	2250	2000	1625	1250	1125					
SAE J517	100R2 TYPE S	HIGH PRESSURE 2 WIRE BRAID	6020	5800	5080	4785	3990	3630	3120	2390	1810	1310	1160	1020				
SAE J517	100R3	2 FABRIC BRAID	1500	1250	1200	1125	1000	875	750	565	375							
SAE J517	100R4	SUCTION																
SAE J517	100R6	1 FABRIC BRAID	500	400	400	400	400	350	300	250	200	150	100	62	56	45	35	
SAE J517	100R7	THERMOPLASTIC	3000	2750	2500	2250	2000	1500	1250	1000								
SAE J517	100R8	HIGH PRESSURE THERMOPLASTIC	5000	5000		4000	3500	2750	2250	2000								
SAE J517	100R9	4 WIRE SPIRAL				4500	4000		3000	3000	2500	2000	2000					
SAE J517	100R10	HIGH PRESSURE 4 WIRE SPIRAL	10000	8750		7500	6250		5000	4000	3000	2500	2500					
SAE J517	100R11	HIGH PRESSURE 6 WIRE SPIRAL	12500	11250		10000	7500		6250	5000	3500	3000	3000	2500				
SAE J517	100R12	4 WIRE SPIRAL				4000	4000	4000	4000	4000	3000	2500	2500					
SAE J517	100R13	5000 PSI WIRE SPIRAL							5000	5000	5000	5000	5000					
SAE J517	100R15	6000 PSI WIRE SPIRAL							6000	6000	6000	6000	6000					
SAE J517	100R16	COMPACT WIRE BRAID		5000	4250	4000	3500	2750	2250	2000	1625							
SAE J517	100R16 TYPE S	HIGH PRESSURE COMPACT WIRE BRAID	6020	5800	5080	4790	3990	3630	3120	2390	1810							
SAE J517	100R17	3000 PSI WIRE BRAID	3000	3000	3000	3000	3000	3000	3000	3000								
SAE J517	100R18	3000 PSI THERMOPLASTIC	3000	3000	3000	3000	3000	3000	3000	3000								

Specification	Hose Style	Description	NOMINAL HOSE INSIDE DIAMETER in INCHES and DASH SIZE															
			1/8 (-3)	3/16 (-4)	1/4 (-5)	5/16 (-6)	3/8 (-7)	1/2 (-8)	5/8 (-10)	3/4 (-12)	1 (-16)	1-1/4 (-20)	1-1/2 (-24)	2 (-32)	2-3/8 (-40)	3 (-48)	200	
SAE J517	100R5	1 WIRE BRAID TEXTILE COVER		3000	3000	2250		2000	1750	1500		800		625	500	350	360	
SAE J517	100R14	1 WIRE BRAID PTFE	1500	1500	1500	1500	1500	1000	800	800	800	800	800	600	600			

EN HOSE WORKING PRESSURES (psi)

Specification	Hose Style	Description	NOMINAL HOSE INSIDE DIAMETER in INCHES and DASH SIZE															
			3/16 (-3)	1/4 (-4)	5/16 (-5)	3/8 (-6)	1/2 (-8)	5/8 (-10)	3/4 (-12)	1 (-16)	1-1/4 (-20)	1-1/2 (-24)	2 (-32)	2-3/8 (-40)	3 (-48)	200		
EN 853	1ST	1 WIRE BRAID STANDARD COVER	3630	3265	3120	2610	2320	1890	1520	1280	915	725	580					
EN 853	1SN	1 WIRE BRAID THIN COVER	3630	3265	3120	2610	2320	1890	1520	1280	915	725	580					
EN 853	2ST	2 WIRE BRAID STANDARD COVER	6020	5800	5075	4785	3990	3625	3120	2395	1815	1305	1160					
EN 853	2SN	2 WIRE BRAID THIN COVER	6020	5800	5075	4785	3990	3625	3120	2395	1815	1305	1160					
EN 856	4SP	4 WIRE SPIRAL		6530		6455	6020	5080	5080	4065	3050	2685	2395					
EN 856	4SH	HIGH PRESSURE 4 WIRE SPIRAL																
EN 857	1SC	COMPACT 1 WIRE BRAID		3265	3120	2610	2325	1890	1525	1280								
EN 857	2SC	COMPACT 2 WIRE BRAID		5805	5080	4790	3990	3630	3120	2395								

2.2.1 Couplings

There are many industry standards which govern the manufacture of hose end couplings. The most common coupling termination end styles are illustrated in Appendix E – Hose Ends.

For additional information, contact your hose and coupling supplier.

2.2 Application Requirements - STAMPED

If the governing standard for a hose assembly is unknown, further application detail must be identified. An effective way to identify application factors that need reviewing prior to defining the proper specifications of a hose assembly is to remember the simple acronym STAMPED.

2.2.2 General

The guide uses the STAMPED process. STAMPED is an acronym and stands for the 7 major information areas required to provide a quality hose assembly for your customer, as follows:

Size - *I.D., O.D. and overall length of the assembly*

To determine the replacement hose I.D., read the layline printing on the side of the original hose. If the original hose layline is painted over or worn off, the original hose must be cut and inside diameter measured for size.

The inside diameter of the hose must be adequate to keep pressure loss to a minimum and avoid damage to the hose due to heat generation or excessive turbulence. The hose should be sized according to the nomographic chart in appendix C

Temperature - *Temperature of the fluid conveyed & and environmental conditions*

When selecting a replacement assembly, two areas of temperature must be considered. These are fluid temperature and ambient temperature. The hose selected must be capable of withstanding the minimum and maximum temperature seen by the system. Care must be taken when routing near hot manifolds and in extreme cases a heat shield may be advisable.

Application - *The conditions under which the hose assembly will be used*

Determine where or how the replacement hose or assembly is to be used. Most often, only a duplicate of the original hose will have to be made. To fulfill the requirements of the application, additional questions may need to be answered, such as:

- Where will the hose be used?
- Excessive abrasion?
- Electrical conductivity requirements?
- Minimum bend radius?
- Unusual mechanical loads?
- Routing requirements?
- Suction required?
- Equipment type?
- Hose construction?

Material - *Fluid being conveyed, type and concentration*

Some applications require specialized oils or chemicals to be conveyed through the system. Hose selection must assure compatibility of the hose tube. For detailed fluid compatibility data, consult your hose and coupling manufacturer.

Pressure - *Pressure to which the assembly will be exposed*

The most important step in the hose selection process is knowing system pressure, including pressure spikes. Hose assembly working pressures must be equal to or greater than the published working pressure will shorten hose life and must be taken into consideration.

Ends - *Termination end style, type, orientation, attachment methods, etc.*

Identify end connections using information in Appendix E

Delivery - *Testing, quality, cleanliness, packaging, and delivery requirements*

Define any special requirements needed.

See Appendix B for the STAMPED template.

Section 3 – Hydraulic Assembly Specifications

Whether it is one hose assembly from an over the counter request or a written work order for multiple hose assemblies from an OEM, it is recommended that the components to be assembled be verified against the requirements of the fabrication order.

3.1 Overall Assembly Length

When establishing proper hose length, motion absorption, hose length changes due to pressure, as well as hose and machine tolerances must be considered. Typical length tolerances for assemblies are shown in the table below.

Assembly Length	Tolerances (decimal in)	Tolerances (fraction in)	Tolerances (mm)
Up through 12 inches (304.8 mm)	0.13	1/8	3.2
Over 12 through 18 inches (304.8 through 457.2 mm)	0.19	3/16	4.8
Over 18 through 36 inches (457.2 through 914.4 mm)	0.25	1/4	6.4
Over 36 inches (914.4 mm)	1%	1%	1%

Unless otherwise specified by the customer, the assembly's overall length is measured from the extreme end of one fitting to the extreme end of the other; except for the O-ring face seal fittings which shall be measured from the sealing face. Where elbow fittings are used, the measurement shall be to the centerline of the sealing surface of the elbow end. For examples please see the illustrations below.

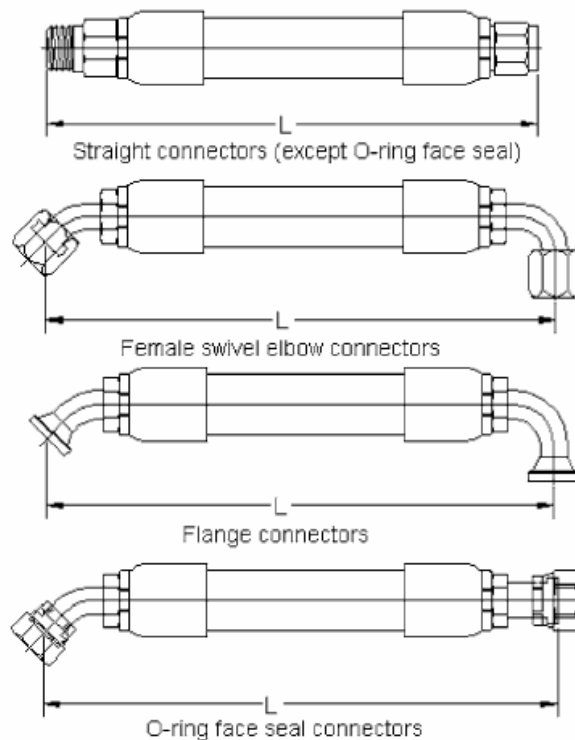

3.2 Hose Assembly Orientation for Offset Elbow Fittings

For double elbow assemblies, it is imperative that the method of description and measurement provide the desired displacement rather than its mirror image. To achieve this, either end may be selected as the reference point, provided angle displacement is determined appropriately (clockwise or counterclockwise) for the reference selected.

As shown in Figure 3.2.1, with the centerline of the near end as a base reference, angular displacement is measured counterclockwise to the centerline of the far end.

FIGURE 3.2.1—NEAR END REFERENCE—MEASURED COUNTER-CLOCKWISE

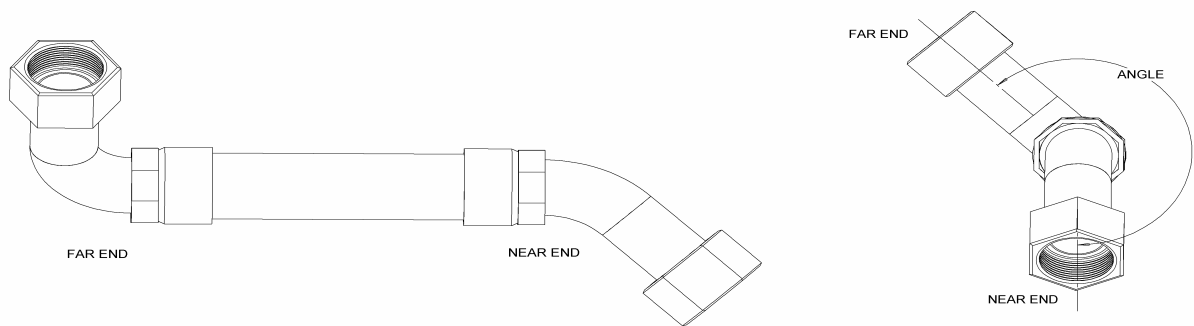

As shown in Figure 3.2.2, with the centerline of the far end as a base reference, angular displacement is measured clockwise to the centerline of the near end.

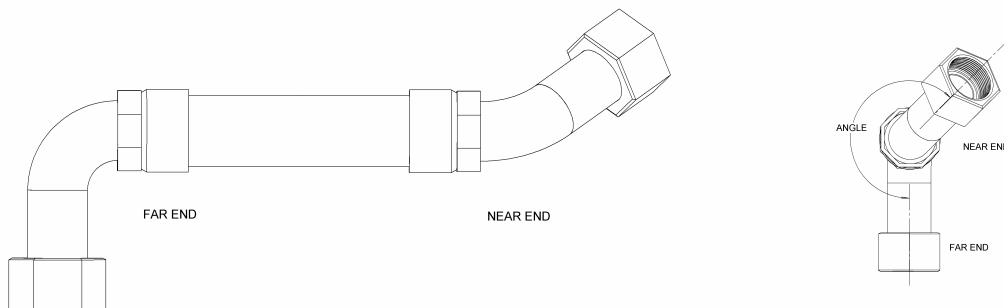

FIGURE 3.2.2—FAR END REFERENCE—MEASURED CLOCKWISE

Displacement angle may have any value up to 360 degrees. Please note that making the angle determination in the wrong direction will result in an unacceptable part.

Unless otherwise specified, a tolerance of ± 3 degrees is acceptable for assembly lengths up to 610 mm inclusive, and ± 5 degrees for assembly lengths over 610 mm.

Try to avoid use of double elbow hose assemblies. Twisting of the hose during installation may occur. The relative location of the natural curvature in the hose may induce a twist during pressure cycling. Twisted hose may reduce the life of the hose assembly.

3.3 Cleanliness

Contaminated oil will reduce the service life of hydraulic systems. Therefore, hose cleanliness is an important part of the fabrication of a hydraulic hose assembly. If contamination is left in the hose after cutting, it is very likely that these particles will work their way into the hydraulic system. Always clean the hose after cutting.

The three methods of specifying cleanliness are:

- Gravimetric analysis (reference ISO 4405)
- Particle counting (reference ISO 4406)
- Maximum particle size (reference ISO 4407)

Customer requirements and the specific application will dictate the required cleanliness level. Finished hose assemblies should be capped immediately to maintain the specified cleanliness level until the assembly is installed.

3.4 Identification (Labeling and Marking)

Some customers require specific markings be applied to the hose assemblies for identification purposes. Labeling and marking requirements should be communicated by the end user. These may include but are not limited to:

- Fabrication Date
- Part number(s)
- Assembly description
- Etc...

3.5 Packaging

Unless otherwise specified by the customer, packaging should afford adequate protection during shipping. Packaging requirements will vary from handing a completed hose to a customer, to capping, bagging and bar coding. Individual customers will each have different requirements. What they all have in common is adequate protection until usage. Check with your customer for specific details.

Section 4 – Quality Plan

The purpose of this section is to outline a quality plan for fabricating hose assemblies. The assurance of an acceptable hose assembly reaching the customer depends upon the quality of the components and the workmanship of the fabricator.

An effective quality control plan is based on statistical sampling principles. Responsibility for supervising the quality plan must be designated. Corrective action procedures must be formalized to deal with nonconformance.

4.1 Sampling Plan

An effective sampling plan is based on the statistical history of a design that demonstrates quality performance and sets confidence levels.

Sampling is performed in an effort to statistically evaluate a product or process against tolerances that are considered acceptable as determined by national standards, customer requirements, etc. This monitoring of product or process with an adequate sampling plan is done in an effort to provide 100% acceptable product to the customer. In an ideal world, if inspection capability is 100% effective, then the only way to assure 100% acceptable product is to inspect everything 100%. Due to practical considerations of time and resources (both manpower and financial), 100% inspection will probably not occur as a standard method of operation.

Many areas or processes may be sampled. These may vary from operation to operation. However, some constants should apply no matter what the operation.

- A. Inspection of incoming material – You cannot guarantee the quality of the outgoing product, if the quality of incoming materials has not been verified.
- B. In process inspection – This may be as simple as inspection of the first assembly produced. Or it may be quite complicated, such as doing a complete dimensional audit on so many pieces per production run and plotting these results on Statistical Process Control (SPC) charts in order to track trends and potential problems.
- C. Final Inspection – This may be relatively simple, such as verifying piece counts before shipping to the customer, or as complicated as checking specific criteria to ensure compliance with the customer's requirements.

Inspection characteristics, the corresponding documentation, and the personnel responsible must be defined, regardless of what is being sampled.

When establishing the frequency of sampling, many factors need to be considered. These include but are not limited to:

- A. Cost
- B. Complexity of process
- C. Application
- D. Liability
- E. Stability of procedure

If a process is very stable as indicated by past performance, the frequency of sampling can be decreased. There is no specific sampling plan that can be considered best suited to all applications.

4.1.1 Dimensional Inspection

- A. Length - Measure the length of a coupled assembly laid out on a flat surface. Unless otherwise shown on the fabrication order (work order), hose assembly length includes the couplings. Length tolerances on coupled assemblies.
- B. Crimped Outside Diameter – With a micrometer or caliper, measure the diameter of the crimped ferrule, in the center between two opposite die faces.
- C. Coupling Orientation - Coupling orientation should be as specified on customer blueprints or fabrication order (work order). (See Section 3.2 - Coupling Orientation.)

4.1.2 Physical Testing

Coupled hose assembly lots should be sampled and tested utilizing an acceptable burst and proof pressure procedure. It is recommended that proof and burst testing be performed in accordance with SAE J517 and SAE J343, as shown below, or an applicable industry standard or customer specification.

- A. Proof Pressure Test – This proof test is conducted at twice the working pressure of the hose unless otherwise specified by the customer. The test pressure shall be maintained for a period of not less than 30 seconds or more than 60 seconds. There shall be no indication of failure or leakage.
- B. Burst Test - Hose assemblies on which the end fittings have been attached less than 30 days shall be subjected to a hydrostatic pressure increased at a constant rate so as to attain the specified minimum burst pressure within a period of not less than 15

seconds nor more than 30 seconds. There shall be no leakage, hose burst, or indication of failure below the specified minimum burst pressure.

4.2 Final Assembly Inspection

All sample assemblies should be visually inspected for substandard quality conditions in the hose or couplings. Visual inspection checkpoints should include but are not limited to the following:

- A. Hose Identification - Size and type must correspond to the fabrication order (work order)
- B. Coupling Identification - Coupling size, type, and product number must correspond to information on the fabrication order (work order) and specifications. Identified with date code, part number, etc. when required.
- C. Inspection Items:
 - Bulge behind the coupling
 - Cocked couplings.
 - Cracked couplings
 - Exposed reinforcement
 - Freedom of swivels
 - General appearance of the assembly
 - Internal contaminants
 - Protective caps or plugs
 - Restriction in the tube
 - Rusted couplings.

4.3 Storage (Labeling, Environment, Time)

Proper storage will maximize hose shelf life.

- A. Store components in a cool, dry area. If stored below freezing, pre-warming may be required prior to handling, testing and placing into service.
- B. Store components in original date-coded containers.
- C. Care should be taken when stacking hose, as its weight can crush hose at the bottom of the stack. The stack could also become unstable, creating a safety hazard.
- D. Avoid exposure to direct sunlight, rain, heaters or proximity to electrical equipment.

4.4 Documentation

If required by the customer, a test certificate may be issued to provide written confirmation that the assembly has been tested, and conforms to certain performance and dimensional criteria. Test results should be maintained and kept on file for five years. Each test certificate should bear a unique number for traceability.

Test certificates may include, but is not limited to the following information:

- A. Test Certificate Number
- B. Customers Name and Purchase Order Number
- C. Suppliers Name and Job Number
- D. Hose Serial Number(s)
- E. Hose details including length, type of hose and diameter
- F. End fitting details with types of ferrules and seals used
- G. Test Date
- H. Test Pressure
- I. Electrical Continuity Conformance
- J. Suppliers Authorization Signature

Other types of documentation may be requested by the customer. All certificates and reports required should accompany the shipment, unless otherwise specified.

Section 5 – Assembly Installation and Procedures

The purpose of this section is to increase awareness on the proper installation and handling of hose assemblies, and to alert fabricators, installers and end-users to the safety hazards in the field.

All hose has a finite life and there are a number of factors, which will reduce its life. The design and use of systems, which contain hoses, require consideration of factors related to specific application requirements.

5.1 Safety Considerations

Below are some potential conditions that can lead to personal injury and property damage. This list is not inclusive. Consider reasonable and feasible means, including those described in this section to reduce the risk of injuries or property damage.

Employers with hose assemblies in fluid systems are encouraged to provide training, including the information in this document, for maintenance personnel and other employees working with and around hoses under pressure.

5.1.1 Media Permeation

Hoses should always be used in well-ventilated areas. Certain media will permeate through hoses that can displace breathable air in confined spaces. Consult the manufacturer if in question.

5.1.2 Fluid Injections

Fine streams of pressurized fluid can penetrate skin and enter a human body. Fluid injection wounds may cause severe tissue damage and loss of limb. Consider the use of guards and shields to reduce the risk of fluid injections.

If a fluid injection occurs, contact a doctor or medical facility at once. Do not delay or treat as a simple cut. Fluid injections are serious injuries and prompt medical treatment is essential. Be sure the doctor knows how to treat this type of injury.

Avoid all contact with escaping fluids. Treat all leaks as though they are pressurized and hot or caustic enough to burn skin.

5.1.3 Whipping Hose

If a pressurized hose or hose fitting comes apart, the loose hose end can flail or whip with great force, and fittings can be thrown off a high speed. This is particularly true in compressible gas or fluid systems. If the risk of hose whipping exists, consider the use of guards and restraints.

5.1.4 Fire and Explosions from Conveyed Fluids

All hydraulic fluids, including many designated as “Fire Resistant”, are flammable (will burn) when exposed to the proper conditions.

Fluids under pressure which escape from system containment, may develop a mist or fine spray that can explode upon contact with a source of ignition (e.g.; open flames, sparks, hot manifolds.) These explosions can be very severe and could cause extensive property damage, serious injury or death. Care should be taken to eliminate all possible ignition sources from contact with escaping fluids, fluid spray or mist, resulting from hydraulic system failures. Select and route hoses to minimize the risk of combustion.

5.1.5 Fire and Explosions from Static-Electric Discharge

Fluid passing through hose can generate static electricity, resulting in static-electric discharge. This may create sparks that can ignite system

fluids or gases in the surrounding atmosphere. Use hose rated for static conductivity or a proper grounding device. Consult manufacturer for proper hose and coupling selection.

5.1.6 Burns from Conveyed Fluids

Fluid media conveyed in certain applications may reach temperatures that can burn human skin. If there is risk of burns from escaping fluid, consider guards and shields to prevent injury, particularly in areas normally occupied by operators

5.1.7 Electrical Shock

Electrocution could occur when a hose assembly conducts electricity to a person. Most hoses are conductive. Many have metal fittings. Even nonconductive hoses can be conduits for electricity if they carry conductive fluids.

Certain applications require hose to be nonconductive to prevent electrical current flow. Other applications require the hose to be sufficiently conductive to drain off static electricity. Hose and fittings must be chosen with these needs in mind. Consult manufacturer with any questions.

Note:

Metal hoses are conductive. Always use proper grounding to minimize the risk of electrical discharge.

Note:

Be aware of routing hydraulic hose near an electrical source. When this cannot be avoided, nonconductive hoses should be considered. SAE J517-100R7 and 100R8 hoses with orange covers marked "Nonconductive" are available for applications requiring nonconductive hose.

5.1.8 Fluid Controlled Mechanisms

Mechanisms controlled by fluids in hoses can become hazardous if a hose fails. For example, when a hose bursts, objects supported by the fluid pressure may fall. If mechanisms are controlled by fluid power, use hose with design characteristics sufficient to minimize the potential risks of property damage or injury.

5.1.9 Hand-held Hydraulic Operated Tools

Extreme care is necessary when connecting hand-held or portable hydraulic powered tools to a hydraulic power source with a hose assembly.

- A. Always use a strain reliever at both ends of the hose assembly to prevent excessive bending, kinking and stress at the coupling to hose interface.
- B. Never use the hose assembly as a means to carry, pull, lift or transport the hydraulic tool or power unit.
- C. Exposed hose near the operator should be covered with a fluid deflection apparatus such as nylon sleeving, for protection against injection injuries should a hose rupture occur.
- D. Operators should be protected with the proper safety equipment such as face masks, leather gloves and safety clothing as dictated by the job, fluid and tools being used.
- E. If the connecting hose assembly could be subjected to external forces that may inflict damage, an appropriate guard should be used.

5.2 Hose Installation and Replacement

The following practices shall be used when installing hose assemblies in new systems or replacing hose assemblies in existing systems.

5.2.1 Pre-Installation Inspection

Before installing hose assemblies, the following shall be examined:

- A. Hose length and routing for compliance with original design.
- B. Correct style, size, length, and visible non-conformity of assembly.
- C. Fitting seats for burrs, nicks or other damage.
- D. Kinked, crushed, flattened, or twisted hose.
- E. Hose should be visually inspected for cleanliness and remove any contaminants that are present.

5.2.2 Handling During Installation

Handle hose with care during installation; bending beyond the minimum bend radius will reduce hose life. Sharp bends at the hose to fitting juncture should be avoided.

5.2.3 Hose Routing

Hose assemblies shall not be installed in a twisted condition. Swivel fittings or a lay line may be used to aid in twist-free installation.

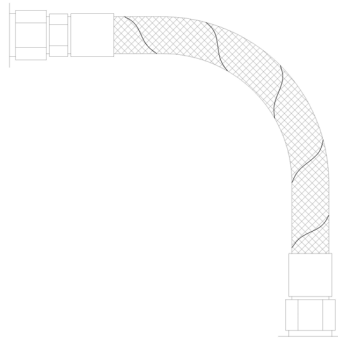

INCORRECT

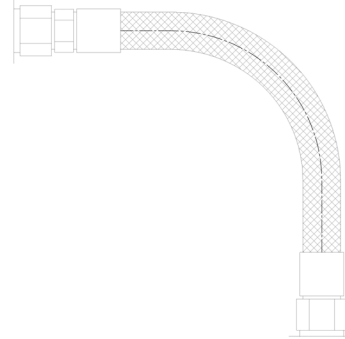

CORRECT

When planning the hose routing use the following practices for optimum performance and more consistent and predictable service life.

Routing at less than minimum bend radius, will reduce the service life of the hose. Use the static or dynamic minimum bend radius according to service conditions. Sharp bends at the hose to fitting juncture should be avoided. Bending radius should not begin closer than one hose diameter to the ferrule.

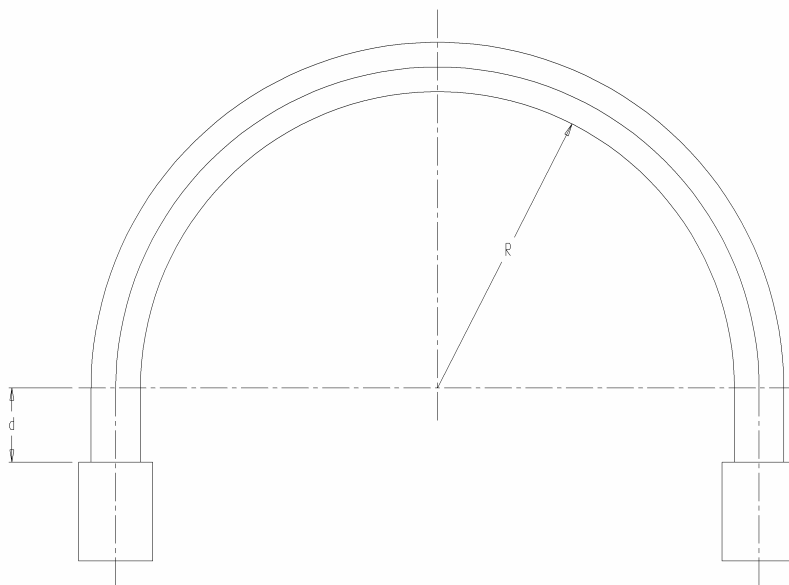

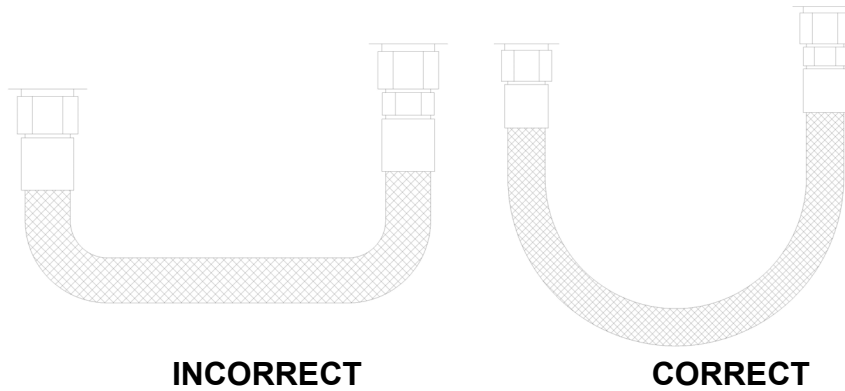

When routing short hose assemblies, it is recommended that a minimum free hose length is always used. Minimum Free Length (**MFL**) is defined as equal to 4 times the hose OD plus half the hose minimum bend radius as a rule of thumb for hydraulic hose assemblies.

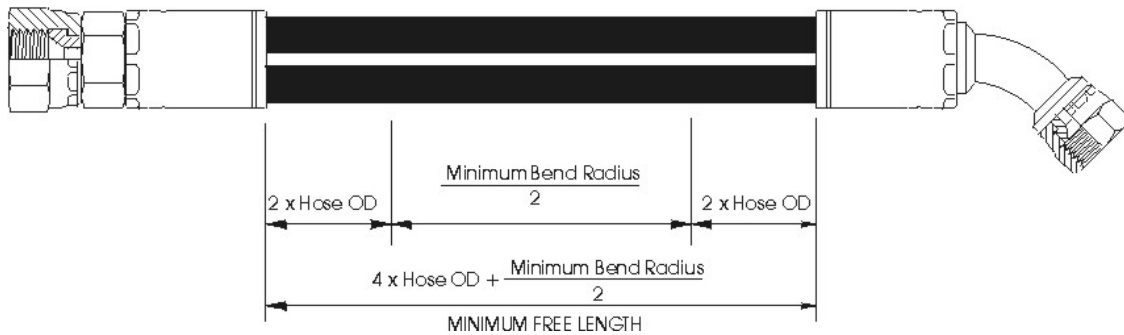

Hose assemblies subject to movement while operating should be installed in such a way that flexing occurs in the same plane.

Necessary restraints and protective devices shall be installed. Such devices shall not create additional stress or wear points.

5.2.4 System Checkouts

It is necessary to eliminate all entrapped air after completing the installation. Follow manufactures' instructions to test the system for possible malfunctions and leaks.

To avoid injury during system checkouts, do not touch any part of the hose assembly when checking for leaks and stay out of potentially hazardous areas while testing hose systems. (See Safety Considerations.)

5.3 Maintenance Inspection

A hose and fitting maintenance program can reduce equipment down time and

maintain peak operating performance.

5.3.1 Inspection Frequency

The nature and severity of the application, past history and manufacturer's recommendations shall be evaluated to determine the frequency of the visual inspections and functional tests. However, in the absence of this information, we recommend a visual inspection be conducted before each shift or at least once a day.

To avoid injury during system checkouts, do not touch any part of the hose assembly when checking for leaks and stay out of potentially hazardous areas while testing hose systems. (See Safety Considerations.)

5.3.2 Visual Inspections

The hose and fittings shall be visually inspected for:

1. Leaks at the hose fittings or in the hose.
2. Exposed, damaged, abraded, or corroded reinforcement.
3. Cracked, damaged, or badly corroded fittings.
4. Other signs of significant deterioration.

If any of these conditions exist, the hose assemblies shall be evaluated for replacement.

5.3.3 Visual Inspections for All Other Components

Hydraulic systems shall be visually inspected for:

1. Leaking ports.
2. Damaged or missing hose clamps, guards, or shields.
3. Excessive dirt and debris around hose.
4. System fluid.
5. Level, type, contamination, condition, and air entrapment or blockage.

If any of these conditions are found, appropriate action shall be taken.

5.3.4 Functional Tests

Functional tests shall be conducted to determine if systems with hose are leak-free and operating properly. Such tests should be conducted in accordance with the manufacturers' recommendations.

APPENDIX A – Glossary

abrasion: external damage to a hose assembly caused by its being rubbed on a foreign object; a wearing away by friction.

accelerated life test: a method designed to approximate in a short time the deteriorating effects obtained under normal service conditions.

adapter, adaptor: 1) fittings of various sizes and materials used to change an end fitting from one type to another type or one size to another. (i.e., a male JIC to male pipe adapter is often attached to a female JIC to create a male end union fitting); 2) the grooved portion of a cam & groove coupling.

adhesion: the strength of bond between cured rubber surfaces or between a cured rubber surface and a non-rubber surface.

adhesion failure: (1) the separation of two bonded surfaces at an interface by a force less than specified in a test method; (2) the separation of two adjoining surfaces due to service conditions.

ambient temperature: the temperature of the atmosphere or medium surrounding an object under consideration.

ambient/atmospheric conditions: The surrounding conditions, such as temperature, pressure, and corrosion, to which a hose assembly is exposed.

amplitude of vibrations and/or lateral movement: the distance a hose assembly deflects laterally to one side from its normal position, when this deflection occurs on both sides of the normal hose centerline.

anchor: a restraint applied to eliminate motion and restrain forces.

angular displacement: displacement of two parts defined by an angle.

anodize, anodized: an electrolytic process used to deposit protective or cosmetic coatings in a variety of colors on metal, primarily used with aluminum.

ANSI: American National Standards Institute.

anti-static: see static conductive.

application working pressure: unique to customer's application. See pressure, working.

application: the service conditions that determine how a hose assembly will be used.

armor: a protective cover slid over and affixed to a hose assembly; used to prevent over bending or for the purpose of protecting hose from severe external environmental conditions such as hot materials, abrasion or traffic.

assembly: a general term referring to any hose coupled with end fittings of any style attached to one or both ends.

ASTM: American Society for Testing and Materials.

attachment: the method of securing an end fitting to a hose (e.g., banding, crimping, swaging, or screw-together-2 piece or 3 piece-style-reusable fittings).

axial movement: compression or elongation along the longitudinal axis.

band: (1) a metal ring that is welded, shrunk, or cast on the outer surface of a hose nipple or fitting; (2) a thin strip of metal used as a non-bolted clamp. See hose clamp.

barb: the portion of a fitting (coupling) that is inserted into the hose, usually comprised of two or more radial serrations or ridges designed to form a redundant seal between the hose and fitting.

barbed and ferrule fitting: a two-piece hose fitting comprised of a barbed insert (nipple), normally with peripheral ridges or backward-slanted barbs, for inserting into a hose and a ferrule, usually crimped or swaged.

basket weave: a braid pattern in which the plaits of wire alternately cross over and under two strands (two over-two under).

bend radius: the radius of a bent section of hose measured to the innermost surface of the curved portion.

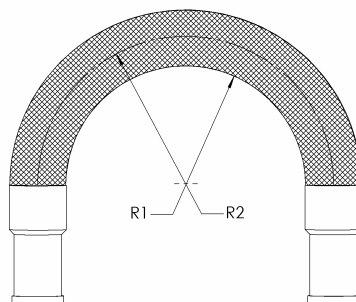

bend radius, minimum: the smallest radius at which a hose can be used.

bend radius, dynamic: the radius at which constant or continuous flexing occurs.

bend radius, static: the smallest fixed radius at which a hose can be subjected.

bending force: an amount of stress required to induce bending around a specified radius and hence, a measure of stiffness.

bleeding: surface exudation. See bloom.

blister: a raised area on the surface or a separation between layers usually creating a void or air-filled space in a vulcanized article.

bloom: a discoloration or change in appearance of the surface of a rubber product caused by the migration of a liquid or solid to the surface, (e.g. sulfur bloom, wax bloom). Not to be confused with dust on the surface from external sources.

body wire: normally a round or flat wire helix embedded in the hose wall to increase strength or to resist collapse.

bore: (1) an internal cylindrical passageway, as of a tube, hose or pipe; (2) the internal diameter of a tube, hose, or pipe.

braid: the woven portion of a hose used as reinforcement to increase pressure rating and add hoop strength. Various materials such as polyester, cotton or metal wire are used. A hose may have one or more braids, outside or between layers of hose material.

braid angle: the angle developed at the intersection of a braid strand and a line parallel to the axis of a hose.

braid coverage: the relative amount of braid material covering a hose expressed as a percent.

braid make up: description of braid (i.e., 32-12-.015, T321 SS), where: 32 is the number of carriers; 12 is the number of wires on each carrier; .015 is the wire diameter in inches; and T321 SS is the material, (Type 321 stainless steel).

braid sleeve/ring/ferrule: a ring made from tube or metal strip placed over the ends of a braided hose to contain the braid wires for attachment of fitting and ferrule, and to immobilize heat affected corrugations.

braided ply: a layer of braided reinforcement.

braid-over-braid: multiple plies of braid having no separating layers.

brand: a mark or symbol identifying or describing a product and/or manufacturer, that is embossed, inlaid or printed.

brass: a family of copper/zinc alloys.

brazing: a process of joining metals using a non-ferrous filler metal having a melting point that is lower than the “parent metals” to be joined, typically over +800°F.

bronze: an alloy of copper, tin and zinc.

buffing (sizing): grinding a surface to obtain dimensional conformance or surface uniformity.

bunch braid: braid applied to hose in bundles rather than flat strands (plaits), usually done to achieve high pressure versus hose weight.

butt weld: process in which the edges or ends of metal sections are butted together and joined by welding.

C of C: certificate of conformance or certificate of compliance; a document, typically signed and dated pertaining to a particular lot or purchase order of item(s), which describes any standards, specifications, tests, materials and/or performance attributes to which the referenced item(s) have met or will meet.

capped end: a hose end covered to protect its internal elements.

carcass: the fabric, cord and/or metal reinforcing section of a hose as distinguished from the hose tube or cover.

casing: see armor.

chafe sleeve: an outer sleeve providing resistance to chafing and external resistance to damage to braided hoses, available in wide variety of materials to meet the application requirements (e.g., chafe sleeves include slip-on, heat shrinkable, integrally extruded).

checking: the short, shallow cracks on the surface of a rubber product resulting from damaging action of environmental conditions.

chemical compatibility: the relative degree to which a material may contact another without corrosion, degradation or adverse change of properties.

chemical resistance: the ability of a particular polymer, rubber compound, or metal to exhibit minimal physical and/or chemical property changes when in contact with one or more chemicals for a specified length of time, at specified concentrations, pressure, and temperature.

clamp: see hose clamp.

cloth impression: see fabric impression.

coefficient of friction: a relative measure of the surface lubricity.

cold flex: see low temperature flexibility.

cold flexibility: relative ease of bending while being exposed to specified low temperature.

cold flow: continued deformation under stress. See creep.

collar: 1) the portion of a fitting that is compressed by swaging or crimping to seal the hose onto the fitting barbs and create a permanent attachment; also called a ferrule. (With reusable fittings, the lock and seal are accomplished mechanically by the collar without swaging or crimping); 2) a raised portion on the hose shank which functions as a connection for a ferrule or other locking device or functions as a hose stop.

combustible liquid: a combustible liquid is one having a flash point at or above +100°F (37.8°C).

compound: the mixture of rubber or plastic and other materials, which are combined to give the desired properties when, used in the manufacture of a product.

compression fitting: see fitting/coupling - Compression

compression set: the deformation which remains in rubber after it has been subjected to and released from a specific compressive stress for a definite period of time at a prescribed temperature. (Compression set measurements are for evaluating creep and stress relaxation properties of rubber.)

concentricity: the uniformity of hose wall thickness as measured in a plane normal to the axis of the hose.

conditioning: the exposure of a specimen under specified conditions, e.g., temperature, humidity, for a specified period of time before testing.

conductive: the ability to transfer electrical potential.

configuration: the combination of fittings on a particular assembly.

control: a product of known characteristics, which is included in a series of tests to provide a basis for evaluation of other products.

controlled flexing: occurs when the hose is being flexed regularly, as in the

case of connections to moving components (e.g., platen presses, thermal growth in pipe work).

copolymer: a blend of two polymers.

core: the inner portion of a hose, usually referring to the material in contact with the medium.

corrosion: the process of material degradation by chemical or electrochemical means.

corrosion resistance: ability of metal components to resist oxidation.

coupling: a frequently used alternative term for fitting.

cover wear: the loss of material during use due to abrasion, cutting or gouging.

cover: the outer component usually intended to protect the carcass of a product.

CPE: chlorinated polyethylene; a rubber elastomer.

cracking: a sharp break or fissure in the surface, generally caused by strain and environmental conditions.

creep: the deformation, in material under stress, which occurs with lapse of time after the immediate deformation.

crimp diameter: the distance across opposite flats after crimping.

crimp/crimping: a fitting attachment method utilizing a number of fingers or dies mounted in a radial configuration. The dies close perpendicular to the hose and fitting axis, compressing the collar, ferrule, or sleeve around the hose.

CSM: chlorosulfonated polyethylene.

cure: the act of vulcanization. See vulcanization.

cut off factor: the hose length to be subtracted from the overall assembly length that allows for the hose coupling end connection extension beyond the end of the hose.

cut resistant: having that characteristic of withstanding the cutting action of sharp object.

cycle-motion: movement from normal to extreme position and return.

date code: any combination of numbers, letters, symbols or other methods used by a manufacturer to identify the time of manufacture of a product.

deburr: to remove ragged edges from the inside diameter of a hose end; an important fabrication step for assembling hose of Teflon® (PTFE) in order to insure a good seal.

deduct length: the amount of fitting length deducted from a hose to result in the desired finished assembly length.

design factor: a ratio used to establish the working pressure of the hose, based on the burst strength of the hose.

design pressure: see application working pressure and pressure, working.

developed length: see overall length.

die: a tool used to swage or crimp a fitting onto a hose. Swage dies usually consist of two halves machined to a predetermined diameter, designed for a specific hose type and size. A crimp die set is typically six to eight “fingers” designed for infinite diameter settings within a range or preset to a specific diameter for a given hose type and size.

displacement: the amount of motion applied to a hose defined as inches for parallel offset and degrees for angular misalignment.

dog-leg assembly: two hose assemblies joined by a common elbow.

DOT: Department of Transportation.

durometer: an instrument for measuring the hardness of rubber and plastic compounds.

durometer hardness: a numerical value, which indicates the resistance to indentation of the blunt indenter of the durometer.

dynamic bend radius: see bend radius, dynamic.

eccentric wall: a wall of varying thickness.

eccentricity: the condition resulting from the inside and outside diameters not having a common center. See eccentric wall.

effective thrust area-hose: cross-sectional area described by the mean diameter of the hose.

effusion: the escape, usually of gases, through a material. See permeation.

elastic limit: the limiting extent to which a body may be deformed and yet return to its original shape after removal of the deforming force.

elastomer: any one of a group of polymeric materials, usually designated thermoset, such as natural rubber, or thermoplastic, which will soften with application of heat.

electrostatic discharge: the sudden discharge of static electricity from an area of buildup to a grounding point.

elongation: the increase in length expressed numerically as a percentage of the initial length.

endurance test: a service or laboratory test, conducted to product failure, usually under normal use conditions.

enlarged end: an end having a bore diameter greater than that of the main body of the hose, in order to accommodate a larger fitting.

EPDM: Ethylene Propylene Diene Monomer; an elastomer.

exothermic: releasing heat.

extrude/extruded/extrusion: forced through the shaping die of an extruder; extrusion may have a solid or hollow cross section.

fabric impression: impression formed on the rubber surface during vulcanization by contact with fabric jacket or wrapper.

fabricator: the producer of hose assemblies.

fatigue: the weakening or deterioration of a material occurring when a repetitious or continuous application of stress causes strain, which could lead to failure.

FDA: United States Food and Drug Administration.

ferrule: a metal cylinder placed over a hose end to affix the fitting to the hose. See braid sleeve, interlocking ferrule, and sleeve.

fire sleeve: slip-on or integrally extruded sleeve used to retard the effects of fire in certain applications; most often made with silicone and/or ceramic fiber.

fitting/coupling: a device attached to the end of the hose to facilitate connection. The following is only a partial list of types of fittings available:

- *Compression Fitting* - a fitting style that seals on a mating tube by compressing an internal ferrule against the tube O.D..
- *Field Attachable Fitting* - a fitting designed to be attached to hose without crimping or swaging. This fitting is not always a Reusable type fitting.
- *Inverted Flare Fitting* - a fitting consisting of a male or female nut, trapped on a tube by flaring the end of the tube material to either 37° or 45°.
- *JIC Fittings* - joint Industrial Council (no longer in existence). An engineering group that established an industry standard fitting design incorporating a 37° mating surface, male and female styles. These standards now governed by SAE.
- *O-ring Fittings* - a fitting that seals by means of an elastomeric ring of a specified material.
- *Pipe Thread Fittings* -
 - NPT- National Pipe Taper. Pipe thread per ANSI B1.20.1
 - NPTF- National Pipe Tapered for Fuels. Same as above except dry-seal per ANSI B1.20.3
 - NPSH- National Pipe Straight Hose per ANSI B1.20.7
 - NPSM- National Pipe Straight Mechanical. Straight thread per ANSI B1.20.1
 - NPSL- National Pipe Straight Loosefit per ANSI B1.20.1
 - BSPP, BSPT- British Standard Pipe Parallel, British Standard Pipe Taper. BS21.
- *Quick Connect Fitting* - a fitting designed to quickly connect and disconnect. These fittings come in many styles and types.
- *Reusable Fitting* - a fitting designed to be attached and unattached to a hose, allowing all or most of the fitting to be reused.
- *Split Flange Fitting* - a fitting consisting of a flange retainer and a flange of two halves. This design allows the flanges to be installed after the retainer has been attached to the hose, making the flange reusable. SAE Code 61 and 62.
- *Tube Fitting* - a hose fitting of which the mating end conforms to a tube

diameter. The mate or male end of a compression fitting.

flammable gases/liquid/media: a flammable gas, including liquefied gas, is one having a closed cup flash point below +100°F (+37.8°C) and a vapor pressure greater than 25 psi. (174.2 KPa).

flat spots: flat areas on the surface of cured hose caused by deformation during vulcanization.

flex cracking: a surface cracking induced by repeated bending and straightening.

flow rate: a volume of media being conveyed in a given time period.

fluid: a gas or liquid medium.

fluid velocity: the speed of fluid through a cross section expressed in length divided by time.

free length: the lineal measurement of hose between fittings or couplings.

frequency: the rate of vibration or flexure in a given time period.

galvanic corrosion: corrosion that occurs on the less noble of two dissimilar metals in direct contact with each other in an electrolyte, such as water, sodium chloride in solution, sulfuric acid, etc.

GPM: gallons per minute.

guide (for piping): a device that supports a pipe radially in all directions, but directs movement.

hardness: resistance to indentation. See durometer hardness.

heat resistance: the property or ability to resist the deteriorating effects of elevated temperatures.

heat-shrink sleeving: tubular thermoplastic sleeve used for chafe protection or identification. The sleeve is slipped over the hose and shrunk down by the application of heat to fit tightly on the hose.

helical wire armor/spring guard: an abrasion resistance device.

helix: a shape formed by spiraling a wire or other reinforcement around the cylindrical body of a hose; typically used in suction hose.

hoop strength: the relative measure of a hose's resistance to collapse of the diameter perpendicular to the hose axis.

hose: a flexible conduit consisting of a tube, reinforcement, and usually an outer cover.

hose assembly: see assembly.

hose clamp: a device used to hold a hose onto a fitting.

hydrostatic testing: the use of liquid pressure to test a hose or hose assembly for leakage, twisting, and/or hose change-in-length.

Hypalon®: a DuPont registered trademark. See CSM.

Hytrel®: a DuPont registered trademark.

I.D.: the abbreviation for inside diameter.

identification yarn: a yarn of single or multiple colors, usually embedded in the hose wall, used to identify the manufacturer.

impression: a design formed during vulcanization in the surface of a hose by a method of transfer, such as fabric impression or molded impression.

impulse service: an application parameter characterized by continuous cyclical pressure changes from low to high.

impulse: an application of force in a manner to produce sudden strain or motion, such as hydraulic pressure applied in a hose.

indentation: 1) the extent of deformation by the indenter point of any one of a number of standard hardness testing instruments; 2) a recess in the surface of a hose.

innercore: the innermost layer of a hose; the hose material in contact with the medium.

insert: optional term for nipple. See nipple.

interstice: a small opening, such as between fibers in a cord or threads in a woven or braided fabric.

IPT: iron pipe threads; a reference to NPT or NPTF.

ISO: International Organization for Standardization.

jacket: a seamless tubular braided or woven ply generally on the outside of a hose.

JIC: see fitting/coupling-JIC.

kinking: a temporary or permanent distortion of the hose induced by bending beyond the minimum bend radius.

lap seam: a seam made by placing the edge of one piece of material extending flat over the edge of the second piece of material.

lay: 1) the direction of advance of any point in a strand for one complete turn; (2) the amount of advance of any point in a strand for one complete turn. See pitch.

light resistance: the ability to retard the destructive action of light.

live length: see free length.

loop installation: the assembly is installed in a loop or “U” shape, and is most often used when frequent and/or large amounts of motion are involved.

low temperature flexibility: the ability of a hose to be flexed, bent or bowed at low temperatures without loss of serviceability.

LPG, LP Gas: the abbreviation for liquefied petroleum gas.

MAWP: see pressure, maximum allowable working.

mandrel: 1) a form, generally of elongated round section used for size and to support hose during fabrications and/or vulcanization. It may be rigid or flexible; 2) a tapered expanding device, fixed in diameter, which is pulled through a shank of a fitting thus expanding the diameter to exert force on the hose between the shank and ferrule.

mandrel built: a hose fabricated and/or vulcanized on a mandrel.

mandrel, flexible: a long, round, smooth rod capable of being coiled in a small diameter. It is used for support during the manufacture of certain types of hose. (The mandrel is made of rubber or plastic material and may have a core of flexible wire to prevent stretching.)

mandrel, rigid: a non-flexible cylindrical form on which a hose may be manufactured.

manufacturer’s identification: a code symbol used on or in some hose to indicate the manufacturer.

mass flow rate: the mass of fluid per unit of time passing through a given cross-section of a flow passage in a given direction.

mean diameter: the midpoint between the inside diameter and the outside diameter of a corrugated/convoluted hose.

mechanical fitting/reusable fitting: a fitting attached to a hose, which can be disassembled and used again.

media, medium: the substance(s) being conveyed through a system.

mender: a fitting or device used to join two sections of hose.

minimum free length (MFL): Calculated as 4 times the hose OD plus half the hose minimum bend radius as a rule of thumb for hydraulic hose assemblies.

misalignment: a condition where two parts do not meet true.

NAHAD: the abbreviation for the Association for Hose & Accessories Distribution.

necking down: a localized decrease in the cross-sectional area of a hose resulting from tension.

Neoprene®: a registered trademark of DuPont.

nipple: the internal member or portion of a hose fitting.

nitrile rubber (NB/Buna-N): a family of acrylonitrile elastomers used extensively for industrial hose.

nominal: a size indicator for reference only.

nomograph: a chart used to compare hose size to flow rate to recommended velocity.

non-conductive: the inability to transfer an electrical charge.

NPT/NPTF: abbreviation for national pipe threads. *See fitting/coupling - Pipe Thread Fittings.*

nylon: a family of polyamide materials.

OAL: see overall length

O.D.: the abbreviation for outside diameter.

OE/OEM: original equipment manufacturer.

off-center: see eccentricity.

offset-lateral, parallel: the distance that the ends of a hose assembly are displaced in relation to each other as the result of connecting two misaligned terminations in a system, or intermittent flexure required in a hose application.

oil resistance: the ability of the materials to withstand exposure to oil.

oil swell: the change in volume of a rubber article resulting from contact with oil.

open steam cure: a method of vulcanizing in which steam comes in direct contact with the product being cured.

operating conditions: the pressure, temperature, motion, and environment to which a hose assembly is subjected.

o-ring fitting: see fitting/coupling, O-Ring.

OS & D hose: the abbreviation for oil suction and discharge hose.

overall length (OAL): the total length of a hose assembly, which consists of the free hose length plus the length of the coupling(s).

oxidation: the reaction of oxygen on a material, usually evidenced by a change in the appearance or feel of the surface or by a change in physical properties.

ozone cracking: the surface cracks, checks or crazing caused by exposure to an atmosphere containing ozone.

ozone resistance: the ability to withstand the deteriorating effects of ozone (generally cracking).

performance test (service test): a test in which the product is used under actual service conditions.

permanent fitting: the type of fitting which, once installed, may not be removed for re-use.

permeation: the process of migration of a substance into and through another, usually the movement of a gas into and through a hose material; the rate of permeation is specific to the substance, temperature, pressure and the material being permeated.

pick: the distance across a group of braid wires from a single carrier, measured

along the axis of the hose.

pig: a mechanical projectile used for cleaning hose.

pin pricked: perforations through the cover of a hose to vent permeating gases.

pitch: 1) the distance from one point on a helix to the corresponding point on the next turn of the helix, measured parallel to the axis; 2) the distance between the two peaks of adjacent corrugation or convolution.

pitted tube: surface depressions on the inner tube of a hose.

plaits: an individual group of reinforcing braid wires/strands.

plating: a material, usually metal, applied to another metal by electroplating, for the purpose of reducing corrosion; typically a more noble metal such as zinc is applied to steel.

ply: an individual layer in hose construction.

pneumatic testing: the use of compressed air to test a hose or hose assembly for leakage, twisting, and/or hose change-in-length. NOTE: Use of high pressure air is extremely hazardous.

polymer: a macromolecular material formed by the chemical combination of monomers, having either the same or different chemical compositions.

pre-production inspection or test: the examination of samples from a trial run of hose to determine adherence to a given specification, for approval to produce.

preset: the process of pressurizing a hose to set the braid and minimize length change in final product.

pressure: force ÷ unit area. For purposes of this document, refers to PSIG (pounds per square inch gauge).

pressure drop: the measure of pressure reduction or loss over a specific length of hose.

pressure, burst: the pressure at which rupture occurs.

pressure, gauge: relative pressure between inside and outside of an assembly.

pressure, maximum allowable working: the maximum pressure at which a hose or hose assembly is designed to be used.

pressure, operating: see pressure, working.

pressure, proof test: a non-destructive pressure test applied to hose assemblies.

pressure, pulsating: a rapid change in pressure above and below the normal base pressure, usually associated with reciprocating type pumps.

pressure, rated working: see pressure, maximum allowable working.

pressure, service: see working pressure.

pressure, shock/spike: the peak value of a sudden increase of pressure in a hydraulic or pneumatic system producing a shock wave.

pressure, working: the maximum pressure to which a hose will be subjected, including the momentary surges in pressure, which can occur during service. Abbreviated as WP.

printed brand: see brand.

propane: see LPG, LP Gas.

psi: pounds per square inch.

PTFE: polytetrafluoroethylene, a high molecular weight fluoroplastic polymer with carbon atoms shielded by fluorine atoms having very strong inter atomic bonds, giving it chemical inertness.

PVC: polyvinyl chloride. A low cost thermoplastic material typically used in the manufacture of industrial hoses. The operating temperature range is -500°F to +1750°F (-295.5°C to +954.4°C).

quality conformance inspection or test: the examination of samples from a production run of hose to determine adherence to given specifications, for acceptance of that production.

RAC: Rubber Association of Canada.

reinforcement: the strengthening members, consisting of either fabric, cord, and/or metal, of a hose. See ply.

reusable fitting/coupling: see fitting/coupling, reusable.

RMA: The Rubber Manufacturers Association, Inc.

SAE: Society of Automotive Engineers.

safety factor: see design factor.

sampling: a process of selecting a portion of a quantity for testing or inspection, selected without regard to quality.

serrations: bumps, barbs, corrugations, or other features that increase the holding power of the device.

service temperature: see working temperature.

shank: that portion of a fitting, which is inserted into the bore of a hose.

shelf/storage life: the period of time prior to use during which a product retains its intended performance capability.

shell: see ferrule.

shock load: a stress created by a sudden force.

simulated service test: see bench test.

skive: the removal of a short length of cover and/or tube to permit the attachment of a fitting directly over the hose reinforcement.

smooth bore: a term used to describe the type of innercore in a hose.

socket: the external member or portion of a hose fitting, commonly used in describing screw-together reusable fittings.

specification: a document setting forth pertinent details of a product.

spiral: a method of applying reinforcement in which there is not interlacing between individual strands of the reinforcement.

spiral angle: the angle developed by the intersection of the helical strand and a line parallel to the axis of a hose. See braid angle.

splice: a method of joining two sections of hose.

splicer: a fitting or device used to join two sections of hose.

spring guard: a helically wound component applied internally or externally to a hose assembly, used for strain relief, abrasion resistance, collapse resistance.

standard: a document, or an object for physical comparison, for defining product characteristics, products, or processes, prepared by a consensus of a properly constituted group of those substantially affected and having the qualifications to prepare the standard for use.

static conductive: having the capability of furnishing a path for a flow of static electricity.

static discharge: see electrostatic discharge.

stem: see nipple.

stress corrosion: a form of corrosion in metal.

surge (spike): a rapid and transient rise in pressure.

swage: the method of fitting attachment that incorporates a set of die halves designed to progressively reduce the collar or ferrule diameter to the required finish dimension by mechanically forcing the fitting into the mating die.

swelling: an increase in volume or linear dimension of a specimen immersed in liquid or exposed to a vapor.

tear resistance: the property of a rubber tube or cover of a hose to resist tearing forces.

Teflon®: a registered trademark of E.I. DuPont. See PTFE.

tube: the innermost continuous all-rubber or plastic element of a hose.

tube fitting: see fitting/coupling-Tube.

tubing: a non-reinforced, homogeneous conduit, generally of circular cross-section.

twist: (1) the turns about the axis, per unit of length, of a fiber, roving yarn, cord, etc. Twist is usually expressed as turns per inch; (2) the turn about the axis of a hose subjected to internal pressure.

vacuum resistance: the measure of a hoses ability to resist negative gauge pressure.

vibration: amplitude motion occurring at a given frequency.

viscosity: the resistance of a material to flow.

volume change: a change in dimensions of a specimen due to exposure to a liquid or vapor.

volume swell: see swelling.

volumetric expansion: the volume increase of hose when subjected to internal pressure.

vulcanization: a process during which a rubber compound, through a change in its chemical structure, improves or extends elastic properties over a greater range of temperature.

weathering: the surface deterioration of a hose cover during outdoor exposure, as shown by checking, cracking, crazing and chalking.

wire reinforced: a hose containing wires to give added strength, increased dimensional stability; crush resistance. See reinforcement.

working temperature: the temperature range of the application, may include the temperature of the fluid conveyed or the environmental conditions the assembly is exposed to in use.

WP: the abbreviation for working pressure.

wrapped cure: a vulcanizing process using a tensioned wrapper (usually of fabric) to apply external pressure. The preceding Glossary of Terms, as utilized in the hose industry, includes some definitions from The Hose Handbook, published by the Rubber Manufacturers Association.

APPENDIX B – Stamped Form

Customer Information:

Company: _____
 Contact: _____
 Address: _____
 Phone: _____

Fax: _____
 E-mail: _____
 P.O.#: _____
 Terms: _____

Size	I.D.	O.D.	Overall Length	Tolerance

Temperature	Materials Conveyed		Environmental Temperature	
	Min.	Max	Min	Max
	°F/°C	°F/°C	°F/°C	°F/°C

Application	Type: _____
-------------	-------------

Material/ Media	Material Conveyed			
	Internal Media		External Environment	

Pressure	Max Working Pressure	Spikes	Vacuum
	PSI/kPa	PSI/kPa	Inches of Hg/kPa

Ends	End	Style/ Material	Size	Threads/Bolts Hole Alignment	Orientation	Attachment Methods	Capped
	1						Y N
	2						Y N

Delivery	Quantity Required:		Date Required:
	Package Type:		
	Pick Up Date:		Ship Via:
	Testing Required:	Y N	Type:
	Certification Required:	Y N	Type:

Special Requirements:

APPENDIX C – Nomographic Flow Chart

Nomographic Chart

Flow Capacity of Hose Assemblies at Recommended Flow Velocities



Based on Formula:

$$\text{Area (Sq.In.)} = \frac{0.321 \times (\text{GPM})}{\text{Velocity (Ft./Sec.)}}$$

Example: To determine the I.D. needed to transport 20 Gallons Per Minute (GPM) fluid volume...

Draw a straight line from 20 GPM on the left to maximum recommended velocity for pressure lines. The line intersects with the middle vertical column indicating a 3/4" I.D. (-12) hose. This is the smallest hose that should be used.

Recommendations are for oils having a maximum viscosity of 315 S.S.U. at 100° F, operating at temperatures between 65° F and 155° F.

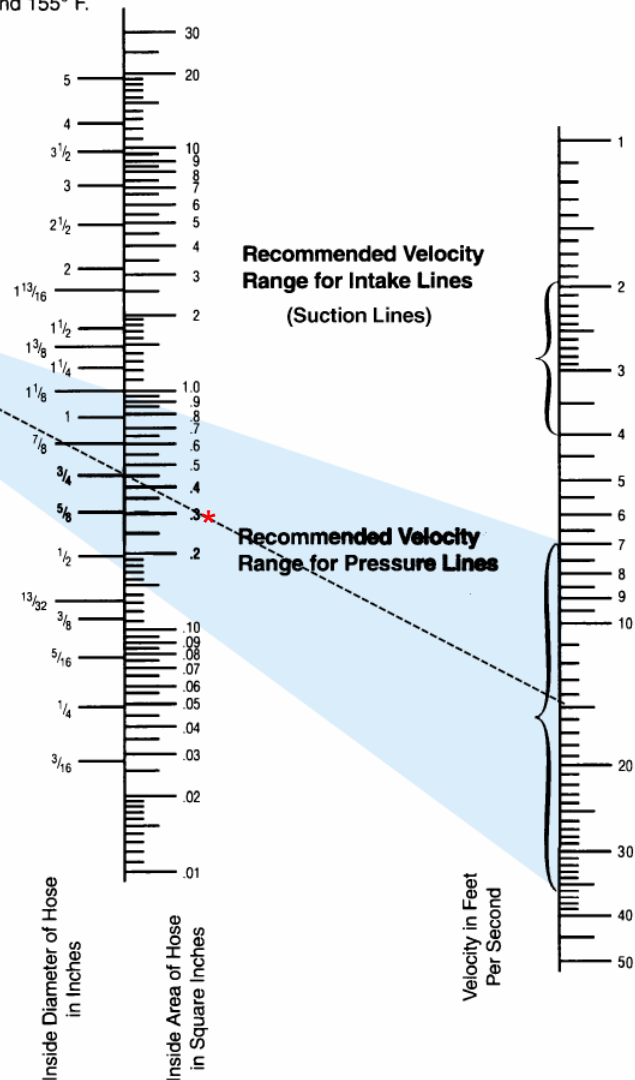

*Maximum pressure line velocity suggestions may vary. Please consult your hose manufacturer for specific recommendations. **(Chart not to scale)**

APPENDIX D – Pressure Conversion Chart

psi	Atms	inches H ₂ O	inches Hg	mm Hg (Torr)	mbar	Bar	Pa (N/m ²)	kPa	MPa
1	0.0681	27.71	2.036	51.715	68.95	0.0689	6895	6.895	0.0069
14.7	1	407.2	29.92	760	1013	1.013	101,325	101.3	0.1013
0.0361	0.00246	1	0.0735	1.866	2.488	0.00249	248.8	0.249	0.00025
0.4912	0.03342	13.61	1	25.4	33.86	0.0339	3386	3.386	0.00339
0.01934	0.001316	0.536	0.0394	1	1.333	0.001333	133.3	0.1333	0.000133
0.0145	0.000987	0.4012	0.0295	0.75	1	0.001	100	0.1	0.0001
14.504	0.987	401.9	29.53	750	1000	1	100,000	100	0.1
0.000145	0.00001	0.00402	0.000295	0.0075	0.01	0.00001	1	0.001	0.000001
0.14504	0.00987	401.9	0.295	7.50	10	0.01	1000	1	0.001
145.04	9.869	401.9	295.3	7500	10,000	10	1,000,000	1000	1

To use this chart:

1. Locate the column with the units you want to convert from.
2. Move DOWN that column until you locate the “1”.
3. Move HORIZONTALLY to the column with the units you want to convert to.
4. MULTIPLY the number in the box by the amount you are changing from to get the converted value.

Length

- 1 cm = 0.3937 in = 10 mm = 0.01 m
- 1 m = 3.2808 ft = 1000 mm = 100 cm
- 1 in = 2.540 cm = 25.40 mm
- 1 ft = 30.48 cm = 0.3048 m

Volume

- 1 L = 0.0353 ft³
- 1 L = 0.2642 gal
- 1 L = 61.025 in³
- 1 L = 0.001 m³
- 1 ft³ = 28.3286 L
- 1 Gal = 0.1336 ft³

Pressure

- 1 psi = 0.0681 atm
- 1 psi = 27.71 in H₂O
- 1 psi = 703.8 mm H₂O
- 1 psi = 2.036 in Hg
- 1 psi = 51.715 mm Hg (torr)
- 1 psi = 68.95 mbar
- 1 psi = 0.0689 bar
- 1 psi = 6895 Pa (n/m²)
- 1 psi = 6.895 kPa
- 1 psi = 0.0069 MPa

APPENDIX E – Hose Ends

37° Flare (JIC)

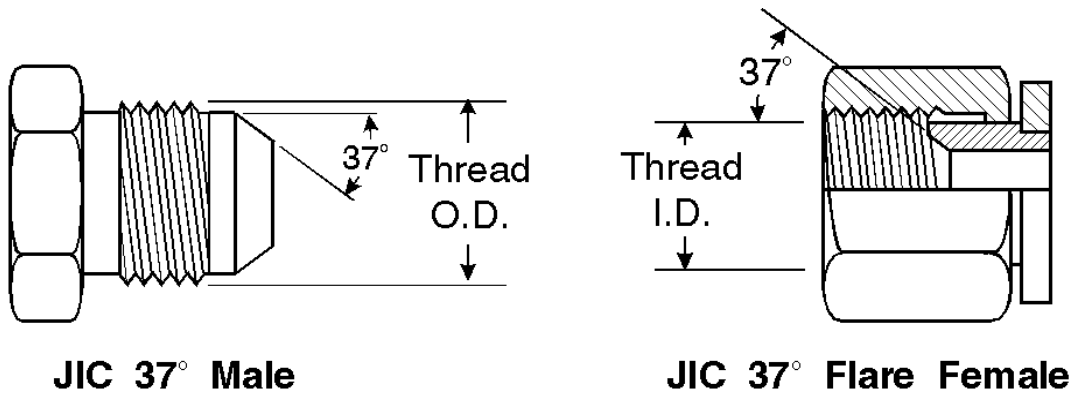

The Society of Automotive Engineers (SAE) specifies a 37° angle flare or seat be used with high pressure hydraulic tubing. These are commonly called JIC couplings.

The JIC 37° flare male will mate with a JIC female only. The JIC male has straight threads and a 37° flare seat. The JIC female has straight threads and a 37° flare seat. The seal is made on the 37° flare seat.

Some sizes have the same threads as the SAE 45° flare. Carefully measure the seat angle to differentiate.

*Note: Some couplings may have dual machined seats (both 37° and 45° seats).

Dash Size	Nominal Size (in.)	Thread Size	Female Thread I.D. (in.)	Male Thread O.D. (in.)
-2	1/8	5/16-24	17/64	5/16
-3	3/16	3/8-24	21/64	3/8
-4	1/4	7/16-20	25/64	7/16
-5	5/16	1/2-20	29/64	1/2
-6	3/8	9/16-18	1/2	9/16
-8	1/2	3/4-16	11/16	3/4
-10	5/8	7/8-14	13/16	7/8
-12	3/4	1-1/16-12	31/32	1-1/16
-14	7/8	1-3/16-12	1-7/64	1-3/16
-16	1	1-5/16-12	1-15/64	1-5/16
-20	1-1/4	1-5/8-12	1-35/64	1-5/8
-24	1-1/2	1-7/8-12	1-51/64	1-7/8
-32	2	2-1/8-12	2-27/64	2-1/2

SAE (45° Flare)

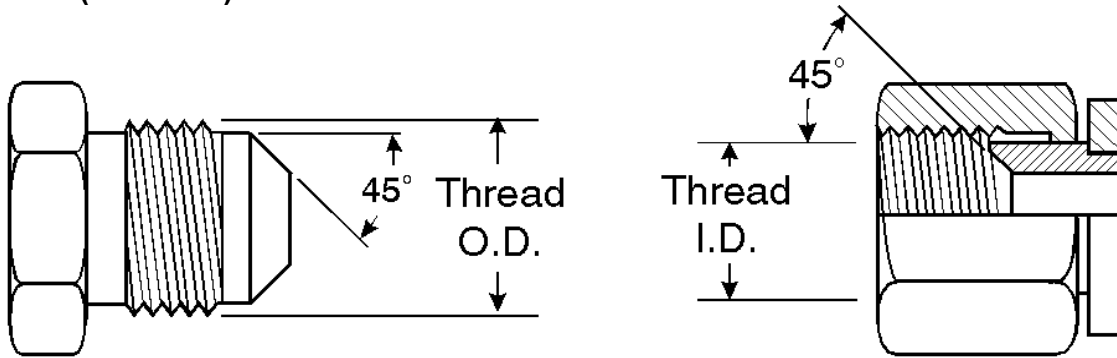

SAE 45° Flare Male

SAE 45° Flare Swivel Female

A term usually applied to fittings having a 45° angle flare or seat. Soft copper tubing is generally used in such applications as it is easily flared to the 45° angle. These are for low pressure applications such as for fuel lines and refrigerant lines.

The SAE 45° flare male will mate with an SAE 45° flare female only. The SAE male has straight threads and a 45° flare seat. The SAE female has straight threads and a 45° flare seat. The seal is made on the 45° flare seat. Some sizes have the same threads as the SAE 37° flare. Carefully measure the seat angle to differentiate.

*Note: Some couplings may have dual machined seats (both 37° and 45° seats).

Dash Size	Nominal Size (in.)	Thread Size	Female Thread I.D. (in.)	Male Thread O.D. (in.)
-2	1/8	5/16-24	17/64	5/16
-3	3/16	3/8-24	21/64	3/8
-4	1/4	7/16-20	25/64	7/16
-5	5/16	1/2-20	29/64	1/2
-6	3/8	5/8-18	9/16	5/8
-7	7/16	11/16-6	5/8	11/16
-8	1/2	3/4-16	11/16	3/4
-10	5/8	7/8-14	13/16	7/8
-12	3/4	1-1/16-12	63/64	1-1/16
-14	7/8	1-1/4-12	1-11/64	1-1/4
-16	1	1-3/8-12	1-19/64	1-3/8

"O" Ring Boss

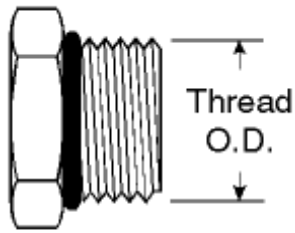

"O" Ring Boss Male

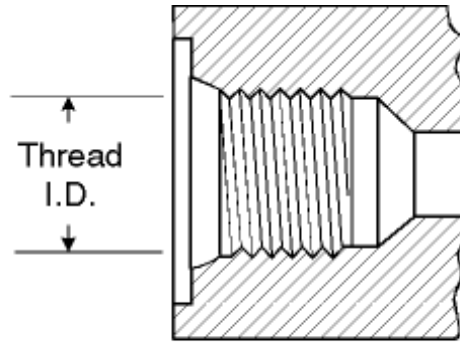

"O" Ring Boss Female Port

The O-ring boss male will mate with an O-ring boss female only. The female is generally found on ports. The male has straight threads and an O-ring. The female has straight threads and a sealing face. The seal is made at the O-ring on the male and the sealing face on the female.

Dash Size	Nominal Size (in.)	Thread Size	Female Thread I.D. (in.)	Male Thread O.D. (in.)
-2	3/16	3/8-24	21/64	3/8
-4	1/4	7/16-20	25/64	7/16
-5	5/16	1/2-20	29/64	1/2
-6	3/8	9/16-18	1/2	9/16
-8	1/2	3/4-16	11/16	3/4
-10	5/8	7/8-14	13/16	7/8
-12	3/4	1-1/16-12	31/32	1-1/16
-14	7/8	1-3/16-12	1-7/64	1-3/16
-16	1	1-5/16-12	1-15/64	1-5/16
-20	1-1/4	1-5/8-12	1-35/64	1-5/8
-24	1-1/2	1-7/8-12	1-51/64	1-7/8
-32	2	2-1/2-12	2-27/64	2-1/2

"O" Ring Flange -- SAE J518

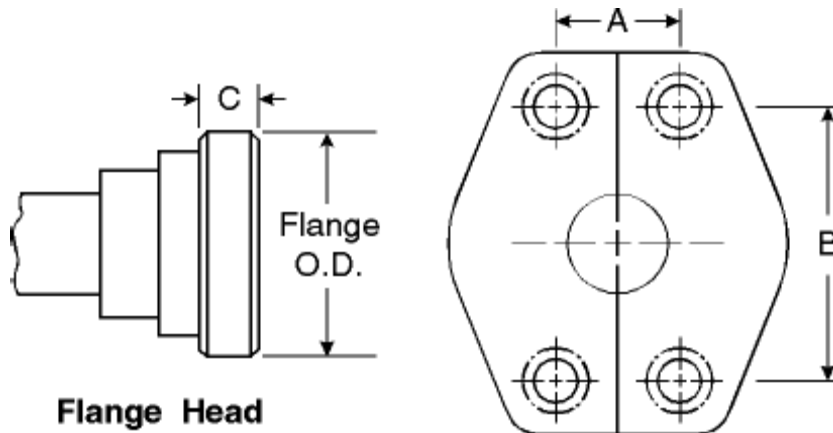

**4-Bolt Split Flange
Bolt Hose Dimensions**

The SAE Code 61 and Code 62 4-Bolt Split Flange is used worldwide, usually as a connection on pumps and motors. There are three exceptions.

1. The -10 size, which is common outside of North America, is not an SAE Standard size.
2. Caterpillar flanges, which are the same flange O.D. as SAE Code 62, have a thicker flange head ("C" dimension in Table).
3. Poclain flanges, which are completely different from SAE flanges.

Nominal Flange Size	Code 61 Flange O.D.	A	B	C	Code 62 Flange O.D.	A	B	C	Caterpillar Flange O.D.	A	B	C
1/2	1.188	.688	1.500	.265	1.250	.718	1.574	.305	-	-	-	-
5/8	1.338	.265	-	.265	-	-	-	-	-	-	-	-
3/4	1.500	.875	1.875	.265	1.625	.937	2.000	.345	1.625	.938	2.000	.560
1	1.750	1.031	2.062	.315	1.875	1.093	2.250	.375	1.875	1.094	2.250	.560
1-1/4	2.000	1.188	2.312	.315	2.125	1.250	2.625	.405	2.125	1.250	2.625	.560
1-1/2	2.375	1.406	2.750	.315	2.500	1.437	3.125	.495	2.500	1.438	3.125	.560
2	2.812	1.688	3.062	.375	3.125	1.750	3.812	.495	3.125	1.750	3.812	.560
2-1/2	3.312	2.000	3.500	.375	-	-	-	-	-	-	-	-
3	4.000	2.438	4.188	.375	-	-	-	-	-	-	-	-
3-1/2	4.500	2.750	4.750	.442	-	-	-	-	-	-	-	-
4	5.000	3.062	5.125	.442	-	-	-	-	-	-	-	-
5	6.000	3.625	6.000	.442	-	-	-	-	-	-	-	-

"O" Ring Face Seal SAE J1453

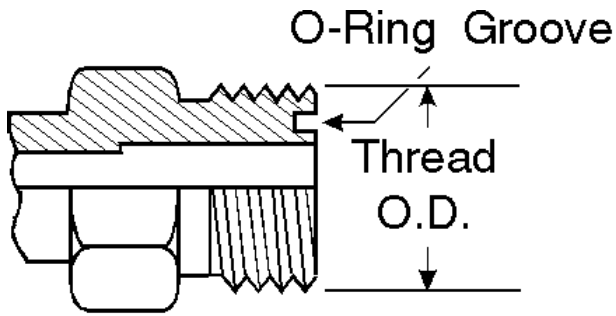

**O-Ring Face Seal
Solid Male**

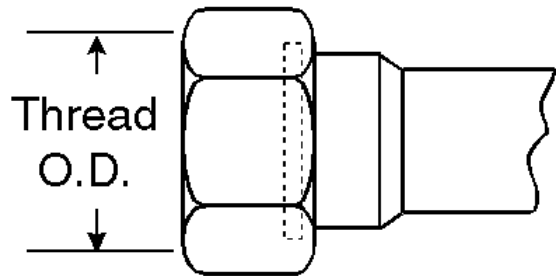

**O-Ring Face Seal
Swivel Female**

A seal is made when the O-ring in the male contacts the flat face on the female. Couplings are intended for hydraulic systems where elastomeric seals are acceptable to overcome leakage and leak resistance is crucial. The solid male O-ring face seal fitting will mate with a swivel female O-ring face seal fitting only. An O-ring rests in the O-ring groove in the male.

Dash Size	Nominal Size (in.)	Thread Size	Female Thread I.D. (in.)	Male Thread O.D. (in.)
-4	1/4	9/16-18	9/16	1/2
-6	3/8	11/16-16	11/16	5/8
-8	1/2	13/16-16	13/16	3/4
-10	5/8	1-14	1	15/16
-12	3/4	1-3/16-12	1-3/16	1-1/8
-16	1	1-7/16-12	1-7/16	1-11/32
-20	1-1/4	1-11/16-12	1-11/16	1-19/32
-24	1-1/2	2-12	2	1-29/32

Pipe Threads

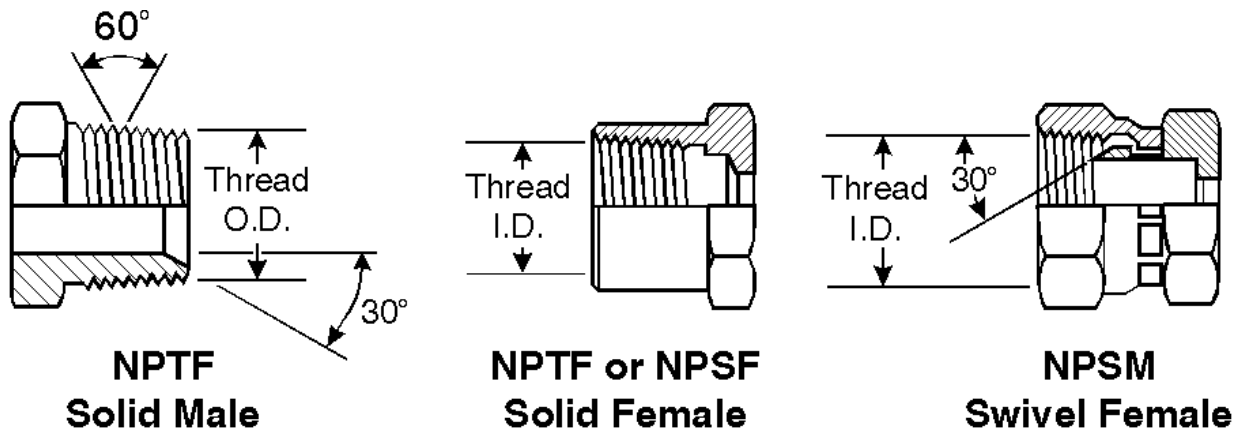

NPTF -- This is a dryseal thread; the National pipe tapered thread for fuels. This is used for both male and female ends. The NPTF male will mate with the NPTF, NPSF, or NPSM female. The NPTF male has tapered threads and a 30° inverted seat. The NPTF female has tapered threads and no seat. The seal takes place by deformation of the threads. The NPSM female has straight threads and a 30° inverted seat. The seal takes place on the 30° seat. The NPTF connector is similar to, but not interchangeable with, the BSPT connector. The thread pitch is different in most sizes. Also, the thread angle is 60° instead of the 55° angle found on BSPT threads.

NPSF -- The National pipe straight thread for fuels. This is sometimes used for female ends and properly mates with the NPTF male end. However, the SAE recommends the NPTF thread in preference to the NPSF for female ends.

Dash Size	Nominal Size (in.)	Thread Size	Female Thread I.D. (in.)	Male Thread O.D. (in.)
-2	1/8	27	23/64	13/32
-4	1/4	18	15/32	35/64
-6	3/8	18	19/32	43/64
-8	1/2	14	3/4	27/32
-12	3/4	14	61/64	1-1/16
-16	1	11-1/2	1-13/64	1-13/64
-20	1-1/4	11-1/2	1-17/32	1-17/32
-24	1-1/2	11-1/2	1-25/32	1-25/32
-32	2	11-1/2	2-1/4	2-3/8

DIN 7631 (DIN 60° Cone)

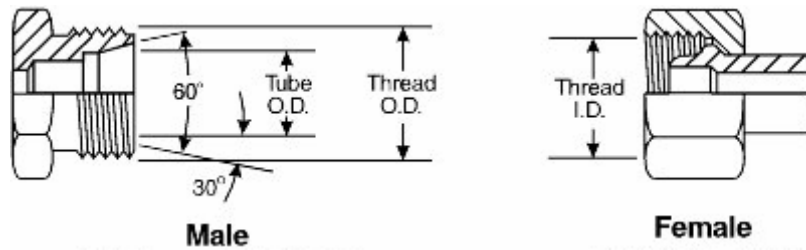

This series combines an internal 60° seat with parallel metric Light series threads. This connection provides a metal-to-metal seal when tightened. This style can be identified by the internal, 60° seat on the male, metric threaded portion.

Metric Thread Size	Female Thread I.D. (mm)	Male Thread O.D. (mm)	Pipe/Tube O.D. (mm)
M12 x 1.5	10.5	12.0	6
M14 x 1.5	12.5	14.0	8
M16 x 1.5	14.5	16.0	10
M18 x 1.5	16.5	18.0	12
M22 x 1.5	20.5	22.0	15
M26 x 1.5	24.5	26.0	18
M30 x 1.5	28.5	30.0	22
M38 x 1.5	36.5	38.0	28
M45 x 1.5	43.5	45.0	35
M52 x 1.5	50.5	52.0	42

DIN 3902 (DIN 24° Cone Light and Heavy Duty)

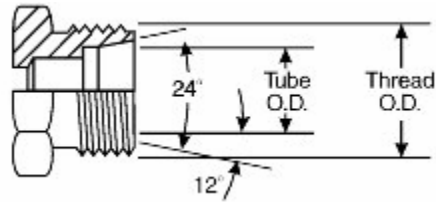

Male 24° Cone

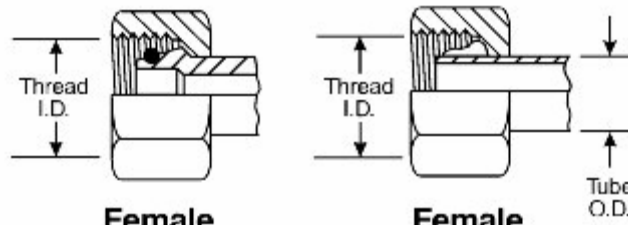

**Female
24° Cone with
“O” Ring**

**Female
Metric Tube**

This connection style consists of a common male and two female options. The male has a straight metric thread, a 24° included angle, and a recessed counterbore that matches the tube OD used with it. In the first female design, a metal-to-metal seal is accomplished as the female nose and male taper are forced against one another. The other option uses an o-ring on the female tapered nose. This creates an o-ring seal as the connection is tightened. Both a heavy and light-duty series are offered. The series can be determined by measuring the seat counterbore, which is the approximate tube outside diameter, and comparing it to the thread size.

Metric Thread Size	Female Thread I.D. (mm)	Male Thread O.D. (mm)	Light Duty Pipe/Tube O.D. (mm)	Heavy Duty Pipe/Tube O.D. (mm)
M12 x 1.5	10.5	12.0	6	-
M14 x 1.5	12.5	14.0	8	6
M16 x 1.5	14.5	16.0	10	8
M18 x 1.5	16.5	18.0	12	10
M20 x 1.5	18.5	20.0	14	12
M22 x 1.5	20.5	22.0	15	14
M24 x 1.5	22.5	24.0	-	16
M26 x 1.5	24.5	26.0	18	-
M30 x 2.0	28.0	30.0	22	20
M36 x 2.0	34.0	36.0	28	25
M42 x 2.0	40.0	42.0	-	30
M45 x 2.0	43.0	45.0	35	-
M52 x 2.0	50.0	52.0	42	38

British Standard Pipe Parallel (BSPP)

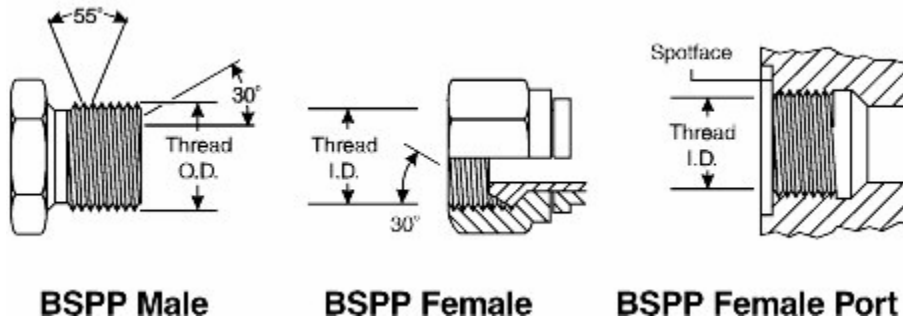

The BSPP male has straight threads and a 30° seat. The female has straight threads and a 30° nose. An o-ring design is also available on the nose from some manufacturers. Sealing can either be metal-to-metal or via an o-ring depending on the design. If the female design is used as a port connection, then an o-ring must be utilized on the male similar in design to the o-ring boss.

Dash Size	Nominal Size (in.)	Thread Size	Female Thread I.D. (in.)	Male Thread O.D. (in.)
-2	1/8	1/8-28	11/32	3/8
-4	1/4	1/4-19	15/32	17/32
-6	3/8	3/8-19	19/32	21/32
-8	1/2	1/2-14	3/4	13/16
-10	5/8	5/8-14	13/16	29/32
-12	3/4	3/4-14	31/32	1-1/32
-16	1	1-11	1-7/32	1-11/32
-20	1-1/4	1-1/4-11	1-17/32	1-21/32
-24	1-1/2	1-1/2-11	1-25/32	1-7/8
-32	2	2-11	2-7/32	2-11/32

British Flat-Face Seal

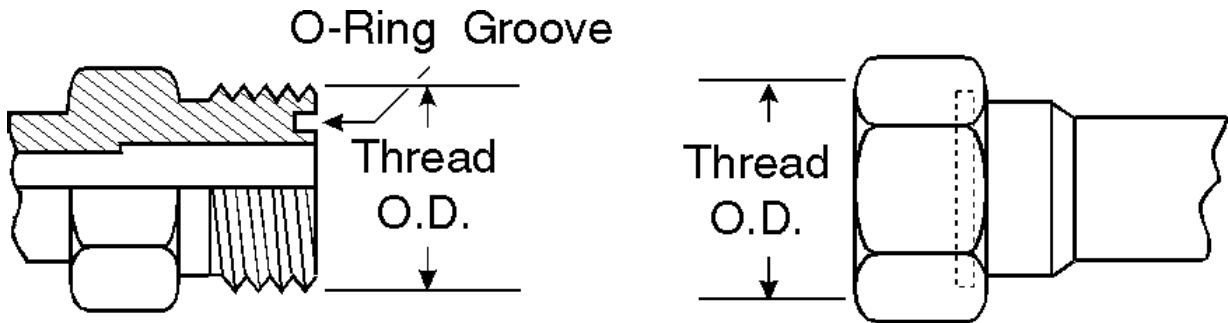

A seal is made when the o-ring in the male contacts the flat face on the female. Couplings are intended for hydraulic systems where elastomeric seals are acceptable to overcome leakage and leak resistance in crucial. Although similar in design to the o-ring face seal, they are not interchangeable.

Dash Size	Nominal Size (in.)	Thread Size	Female Thread I.D. (in.)	Male Thread O.D. (in.)
-6	3/8	3/8-19	19/32	21/32
-8	1/2	1/2-14	3/4	13/16
-12	3/4	3/4-14	31/32	1-1/32

JIS 30° Inverted Seat (Parallel Pipe and Metric Threads)

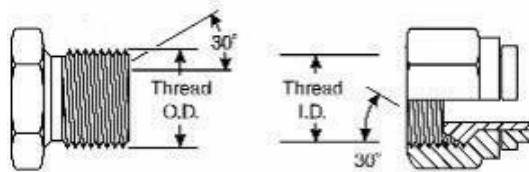

The JIS inverted seat connection is available with two different thread styles. The parallel pipe thread design operates similarly to the BSPP connection. However, please consult your hose end supplier for interchangeability recommendations. The metric threaded design is identical to the parallel pipe design except for thread differences.

Parallel Pipe Threads				
Dash Size	Nominal Size (in.)	Thread Size	Female Thread I.D. (in.)	Male Thread O.D. (in.)
-4	1/4	1/4-19	15/32	17/32
-6	3/8	3/8-19	19/32	21/32
-8	1/2	1/2-14	3/4	13/16
-12	3/4	3/4-14	31/32	1-1/32
-16	1	1-11	1-7/32	1-11/32
-20	1-1/4	1-1/4-11	1-17/32	1-21/32
-24	1-1/2	1-1/2-11	1-25/32	1-7/8
-32	2	2-11	2-7/32	2-11/32

Metric Threads				
Dash Size Equivalent	Nominal Size (mm)	Thread Size	Female Thread I.D. (mm)	Male Thread O.D. (mm)
-4	6	M14 x 1.5	12.5	14.0
-6	9	M18 x 1.5	16.5	18.0
-8	12	M22 x 1.5	20.5	22.0
-12	19	M30 x 1.5	28.5	30.0
-16	25	M33 x 1.5	31.5	33.0
-20	32	M42 x 1.5	40.5	42.0

British Standard Pipe Tapered (BSPT) / Japanese Tapered Pipe Thread

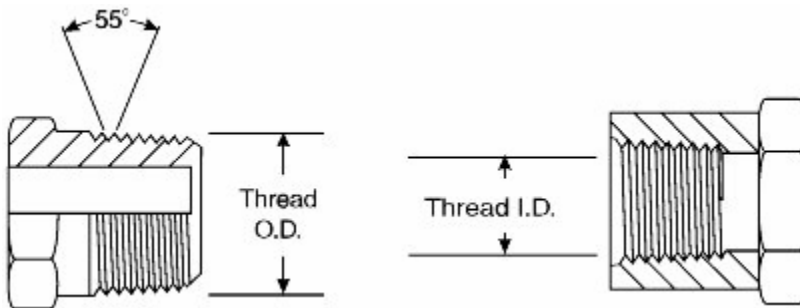

The BSPT is similar to NPTF, but not interchangeable due to thread differences. Sealing, like the NPTF, is accomplished on the threads. BSPT is identical and fully interchangeable with Japanese Tapered Pipe Thread.

Dash Size	Nominal Size (in.)	Thread Size	Female Thread I.D. (in.)	Male Thread O.D. (in.)
-2	1/8	1/8-28	11/32	3/8
-4	1/4	1/4-19	15/32	17/32
-6	3/8	3/8-19	19/32	21/32
-8	1/2	1/2-14	3/4	13/16
-10	5/8	5/8-14	13/16	29/32
-12	3/4	3/4-14	31/32	1-1/32
-16	1	1-11	1-7/32	1-11/32
-20	1-1/4	1-1/4-11	1-17/32	1-21/32
-24	1-1/2	1-1/2-11	1-25/32	1-7/8
-32	2	2-11	2-7/32	2-11/32

French GAZ 24° Cone

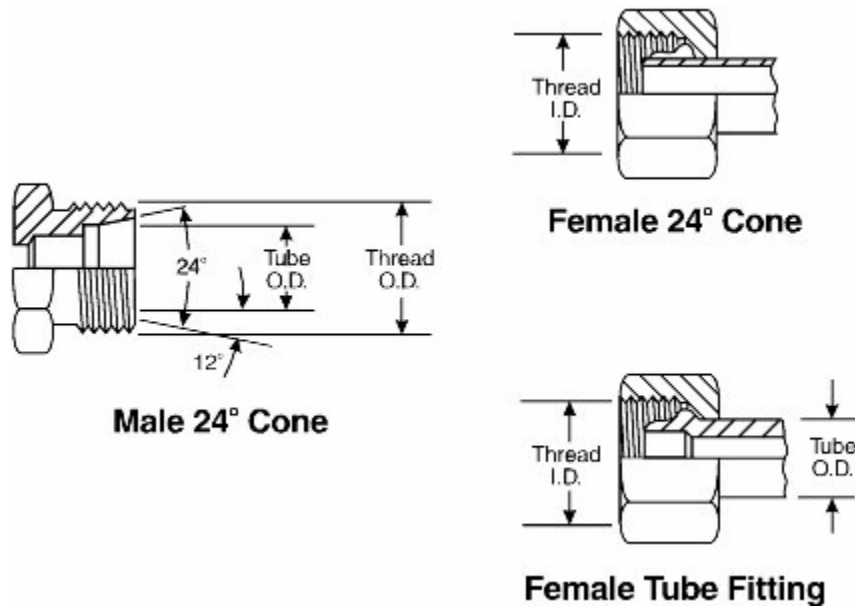

This end connection is similar to the DIN 24° cone; however, they are not interchangeable. Even though the sealing angles are the same, the threads are different.

Metric Thread Size	Female Thread I.D. (mm)	Male Thread O.D. (mm)	Pipe/Tube O.D. (mm)
M20 x 1.5	18.5	20.0	13.25
M24 x 1.5	22.5	24.0	16.75
M30 x 1.5	28.5	30.0	21.25
M36 x 2.0	34.5	36.0	26.75
M45 x 2.0	43.5	45.0	33.50
M52 x 2.0	50.5	52.0	42.25
M58 x 2.0	55.0	58.0	48.25

French GAZ Poclairn 24° Flange

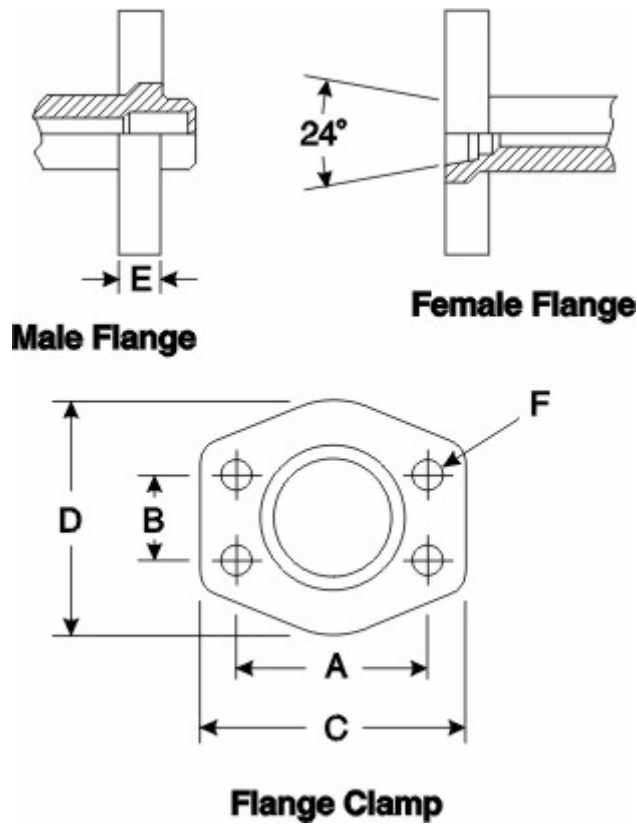

This flange differs from standard SAE flanges in that it has a lip that protrudes from the male flange face with a 24° angle. This lip fits into mating the female flange seat and provides the metal-to-metal seal when the bolts are tightened.

Nominal Size (in.)	A (in.)	B (in.)	C (in.)	D (in.)	E (in.)	F (in.)
1/2	1.57	.72	2.20	1.89	.55	.35
5/8	1.57	.72	2.20	1.89	.55	.35
3/4	2.00	.94	2.75	2.38	.71	.43

Metric Standpipe Assembly

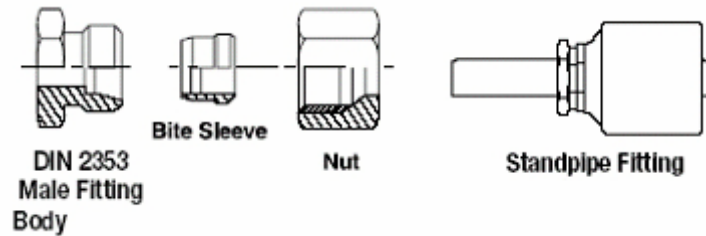

A metric standpipe assembly is comprised of three components attached to a male fitting. The components are: a Standpipe tube, Bite Sleeve, and Metric Nut. The nut is placed over the Standpipe, followed by the Bite Sleeve. For DIN light assemblies, a DIN light metric nut is used. For DIN heavy assemblies, a DIN heavy metric nut is used. The Bite Sleeve and Standpipe are selected on the basis of tube O.D. required.

Metric Standpipe DIN Tube O.D. (mm)	Bite Sleeve DIN Tube O.D. (mm)	Metric Light Nut Thread	Metric Heavy Nut Thread
6	6	M12 x 1.5	-
8	8	M14 x 1.5	M16 x 1.5
10	10	M16 x 1.5	M18 x 1.5
12	12	M18 x 1.5	M20 x 1.5
15	15	M22 x 1.5	-
16	16	-	M24 x 1.5
18	18	M26 x 1.5	-
20	20	-	M30 x 2.0
22	22	M30 x 2.0	-
25	25		M36 x 2.0
28	28	M36 x 2.0	-
30	30	-	M42 x 2.0
35	35	M45 x 2.0	-
38	38	-	M52 x 2.0
42	42	M52 x 2.0	-

Komatsu 30° Flare Parallel Threads

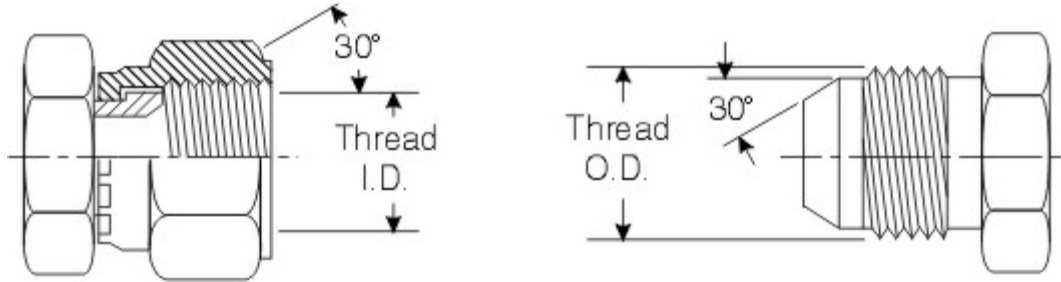

The Komatsu 30° flare is similar to the 37° JIC flare connection except for two things. The seat angle is 30° instead of 37°, and the threads are metric.

Dash Size	Nominal Size (in.)	Nominal Size (mm)	Metric Thread Size	Female Thread I.D. (mm)	Male Thread O.D. (mm)
-6	3/8	9.5	M18 x 1.5	18.5	20.0
-8	1/2	13	M22 x 1.5	22.5	24.0
-10	5/8	16	M24 x 1.5	28.5	30.0
-12	3/4	19	M30 x 1.5	34.5	36.0
-16	1	25	M33 x 1.5	43.5	45.0
-20	1-1/4	32	M36 x 1.5	50.5	52.0
-24	1-1/2	38	M42 x 1.5	55.0	58.0

Kobelco Metric Bite Sleeve

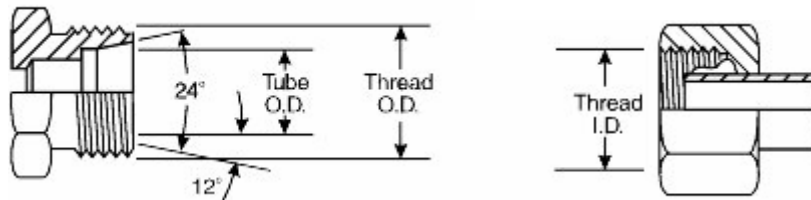

These are similar to the German DIN 24° Cone, but the DIN style uses coarser threads. Therefore, the Kobelco and DIN connections are not interchangeable.

Dash Size	Metric Thread Size	Female Thread I.D. (mm)	Male Thread O.D. (mm)
-22	M30 x 1.5	28.0	30.0
-28	M36 x 1.5	34.0	36.0
-35	M45 x 1.5	43.0	45.0

APPENDIX F – References

ANSI

American National Standards Institute
Attn: Customer Service
25 West 43rd Street
New York, NY 10036
Phone: (212) 642-4900
Fax: (212) 398-0023
E-mail: info@ansi.org
Internet: <http://www.ansi.org>

ASME

American Society for Mechanical Engineers
22 Law Drive
Box 2900
Fairfield, NJ 07007-2900
Phone: (800) 843-2763; (973) 882-1167
Fax: (973) 882-1717; (973) 882-5155
E-mail: infocentral@asme.org
Internet: <http://www.asme.org>

ASQ

American Society for Quality
600 North Plankinton Avenue
Milwaukee, WI 53203
Phone: (800) 248-1946
Fax: (414) 272-1734
E-mail: help@asq.org
Internet: <http://www.asq.org>

ASTM International

100 Barr Harbor Drive
West Conshohocken, PA 19428-2959
Phone: (610) 832-9585
Fax: (610) 832-9555
E-mail: service@astm.org
Internet: <http://www.astm.org>

Document Center, Inc.

111 Industrial Road, Suite 9
Belmont, CA 94002
Phone: (650) 591-7600
Fax: (650) 591-7617
E-mail: mailto:info@document-center.com
Internet: <http://www.document-center.com/>

Global Engineering Documents

15 Inverness Way East
Englewood, CO 80112
Phone: (800) 854-7179; (303) 397-7956
Fax: (303) 397-2740
Email: global@ihs.com
Internet: <http://www.ihs.com>

Government Printing Office

732 North Capitol St. NW
Washington, DC 20401
Phone: (202) 512-0000
Email: webteam@gpo.gov
Internet: <http://www.gpo.gov>

ISO

International Organization for Standardization (ISO)
1, rue de Varembé, Case postale 56
CH-1211 Geneva 20, Switzerland
Phone: +41 22 749 01 11
Fax: +41 22 733 34 30
Internet: <http://www.iso.org>

NAHAD

The Association for Hose and Accessories Distribution
105 Eastern Ave. Suite 104
Annapolis, MD 21403-3300
Phone: (410) 263-1014
Fax: (410) 263-1659
E-mail: nahad@nahad.org
Internet: <http://www.nahad.org>

RMA

Rubber Manufacturers Association c/o The Mail Room
P.O. Box 3147
Medina, OH 44258-3147
Phone: (800) 325-5095; (330) 723-2978
Fax: (330) 725-0576
E-mail: info@rma.org
Internet: <http://www.rma.org>

SAE

Society of Automotive Engineers
400 Commonwealth Drive
Warrendale, PA 15096-0001
Phone: (877) 606-7323;
Fax: (724) 776-0790
Email: customerservice@sae.org
Internet: <http://www.sae.org>

UL

Underwriters Laboratory
333 Pfingsten Road
Northbrook, IL 60062-2096 USA
Telephone: (847) 272-8800
Fax: (847) 272-8129

NOTES:

NOTES:
